

# The National Association for School and Youth Group Karting



## Handbook and Regulations 2021

This handbook has been copied and distributed with the  
support of



Printibility,  
26 Trinity Avenue  
Enfield  
EN1 1HS  
Tel: 020 8803 4600  
mail@printibility.co.uk  
www.printibility.co.uk

## NatSKA Directors

### Secretary

Val Newton

Email: [secretary@natska.co.uk](mailto:secretary@natska.co.uk)

### Chairman

Gaynor Heath

Email: [chairman@natska.co.uk](mailto:chairman@natska.co.uk)

### Treasurer

Gail Fitchett

Email: [treasurer@natska.co.uk](mailto:treasurer@natska.co.uk)

### Membership & Licensing

David Speed

Email: [licences@natska.co.uk](mailto:licences@natska.co.uk)

### Competition Secretary

Kevin Fitchett

Email: [compsec@natska.co.uk](mailto:compsec@natska.co.uk)

### Technical Director

Stuart Hammond

Email: [technical@natska.co.uk](mailto:technical@natska.co.uk)

### Development Director

Stephen Keirle

Email: [development@natska.co.uk](mailto:development@natska.co.uk)

## NatSKA Committee

### Child Safeguarding Officers

Carol Speed

Stuart Hammond

### Entries Coordinator

Stuart Hammond

[entries@natska.co.uk](mailto:entries@natska.co.uk)

### Novice Development and Training

Jordan Brown

### Media Team

Maria Bright

Caroline Wardell

[media@natska.co.uk](mailto:media@natska.co.uk)

### Covid Officer

Val Newton

### Assistant Treasurer

Position Vacant

### Safety Officer

Position Vacant

## NatSKA Contacts

### Website

Stephen Keirle

### Timekeepers

Gaynor Heath

Stephen Keirle

# NatSKA

**The National Association for School and  
Youth Group Karting**

# Handbook 2021

**NatSKA is a Company Limited by Guarantee**

**Company Number: 03570657**

**Registered Office:**

**22 Brampton Avenue,  
Macclesfield, SK10 3DY**

**To bring order and method to any sport, it needs to be run in accordance with certain regulations and agreed standards. Team Leaders whose groups are not yet involved in NatSKA should know these before they recommend that a kart building and racing project is set up. All groups participating shall abide by the rules as set out in this Handbook. If further clarification regarding any of these rules is needed please consult with the Technical Director or any other Director of the Association.**

**Copyright: NatSKA Ltd**

# **SAFEGUARDING**

## **Introduction**

The National Association of School and Youth Group Karting (NatSKA) believes every child, young person, and adult who participates in motorsport should be able to do so in an enjoyable and safe environment and be protected from abuse. We support the assertion that safeguarding is everyone's responsibility and recognise our responsibility to safeguard the welfare of all children, young people and adults by seeking to protect them from all forms of neglect and abuse.

We are therefore committed to providing a safe environment for all children, young people and adults to participate at all levels within the sport to the best of their abilities.

## **Policy statement**

We seek to ensure the safety and wellbeing of all children and adults and to protect them from harm or abuse when they engage in any activities conducted with NatSKA. This safeguarding policy encompasses the Motorsport UK Safeguarding policies including (but not limited to):

- Children;
- Adults at risk;
- Anti-bullying;
- Equality, diversity and inclusion;
- Social Media;
- Managing allegations against volunteers;
- recording and retention of safeguarding records;
- Non-recent abuse;

This policy is promoted to all adults and young people who participate in motorsport with NatSKA.

## **Safeguarding statement**

NatSKA recognises our moral and statutory responsibility to safeguard and promote the welfare of all children and adults. We endeavour to provide a safe and welcoming environment where they are respected and valued. We are alert to the signs of abuse and neglect and follow our procedures to ensure that they receive effective support, protection and justice.

The procedures contained in this policy apply to all who participate in our events.

### **Policy principles**

- The welfare of the child is paramount
- All children and adults, regardless of age, ability, culture, race, language, religious beliefs, sexual or gender identity, have equal rights to protection
- Safeguarding is everybody's responsibility. We all have a responsibility to respond positively in response to any concerns, suspicion or disclosure that may suggest a child or adult is at risk of harm
- Children and volunteers involved in child protection issues will receive appropriate support
- Volunteers with roles and responsibilities for children and young people will be subject to appropriate volunteering checks and safeguarding training
- Volunteers of our organisation will receive appropriate learning and training opportunities to ensure they can make informed and confident responses to safeguarding issues
- We are committed to providing a safe and positive environment for all children, young people and adults to participate to the best of their abilities for as long as they choose to do so

For the purposes of this statement:

A NatSKA Volunteer - any person signed on as an official.

A NatSKA Adult Member - any person signed on as an adult helper in a support role.



## Contents

### **Part A: Operating Regulations**

A1	The Company	1
A2	Objects	1
A3	Rules and Regulations	1
A4	Membership	1
A5	Voting Rights	2
A6	Subscriptions	3
A7	Records Officer	3
A8	Annual General Meeting	3
A9	Extraordinary General Meeting	3
A10	Directors Meeting	3
A11	Quorum	3
A12	Directors & Committee Members	3
A13	Accounts	4
A14	National Licence Scheme	4
A15	Medical Declaration	6
A16	Expenses and Payment	6

### **Part B: NatSKA Kart Meetings**

B1	Generally	7
B2	Insurance	7
B3	Track Safety and Inspection	8
B4	Equipment	8
B5	Officials	8
B6	Rights and Duties of Organisers	11
B7	Signals	11
B8	Licences	12
B9	Eligibility	13
B10	Drivers	14
B11	Helmets and Clothing	15
B12	Drivers' Conduct	16
B13	Race Procedure	17
B14	Penalties	20
B15	Protests and Appeals	20
B16	Additional Notes for Organisers	20
B17	Useful Checks	21
B18	Spectators and Dogs	21
B19	Definitions	21
B20	Lap Scoring	22
B21	Novice	22
B22	Trophies	22
B23	Dates	23
B24	Grid Passes	23

## **Part C: Kart Specifications**

C1	Chassis	24
C2	Wheels and Tyres	24
C3	Bodywork	24
C4	Bumpers	24
C5	Steering	26
C6	Brakes	26
C7	Exhausts	26
C8	Pedals	27
C9	Transmission and Chain Guards	27
C10	Flooring	27
C11	Seating	27
C12	Self Starting Karts	28
C13	Fuel and Oil Containers	28
C14	Fuels Pipes and Feeds	28
C15	Fuel and Oils	28
C16	Number Plates	28
C17	Aerofoils	28
C18	Suppression	28
C19	Rear Axle	28
C20	Hand Controls for Disabled Drivers	29
C21	Radiator	29
C22	Transponders	29

## **Part D: Kart Class Rules and Engine Specification**

D1	Generally	30
D2	Definitions	30
D3	Tuning Modifications in all Classes Except 5, 10, 11, 12 and 14	30
D4	Kart Classes	30
D5	Number Plates	38
D6	Numbers and Plate Colours	39
D7	Classes which can be combined for Event Purposes	39

Appendices can be found at the end of the document



## Part A: Operating Regulations

### A1. The Company

The name of the Company shall be NatSKA Limited, herein after called "NatSKA".

### A2. Objects

**A2.1** The objects of NatSKA shall be:

**A2.1.1** to encourage the formation and development of karting in schools and recognised youth groups;

**A2.1.2** to encourage the development of design and technological skills as a necessary branch of education

**A2.1.3** to provide opportunity for free exchange of ideas and information between clubs;

**A2.1.4** to standardise karting procedures and choice of engine.

### A3. Rules and Regulations

**A3.1** For the use of any rules and regulations the following books should be referred to in order:-

1. Final Instructions
2. Supplemental Regulations
3. NatSKA Handbook and Regulations
4. Motorsport UK Yearbook (Competitors and Officials)
5. Motorsport UK Kart Year Book
6. Any Manufacturers Engine Fiche and/or Technical regulations.

The information and instructions in the Final Instructions and Supplemental Regulations cannot override any rules in the NatSKA Handbook, unless it is a specific circuit safety regulation. Should a rule be found in a publication earlier in the list, this overrides any rules found in publications later in the list. Shall no answer to any specific question be found, then it is not allowed.

**A3.2** The rules, regulations and contents as contained within the NatSKA Handbook and Regulations are ratified by the Members of NatSKA annually at each AGM. The NatSKA Handbook and Regulations are ratified by Motorsport UK each year after the AGM. The NatSKA Handbook and Regulations in their entirety cannot be modified and remain in force until the next AGM or EGM unless

specific safety changes are required or by agreement of all NatSKA members. The only other time the regulations can be modified is by a specific written instruction of the Motorsport UK Governing Body. The Kart Class specifications may be altered by the directors during a racing season only if a manufacturers or significant supply change occurs during that racing season.

**A3.3** After the AGM any references to the Motorsport UK regulations or text in Motorsport UK publications will be amended and updated accordingly to reflect the current published versions.

### A4. Membership

**A4.1** There shall be membership classes as defined in Section 3 of the company articles.

**A4.1.1** "Directors" shall undertake the management of NatSKA and shall be deemed as the Directors of NatSKA. "Committee Members" shall undertake to assist the directors in the management of NatSKA. "Organisers" shall assist the Directors and Committee Members in the day to day running of a race meeting.

**A4.1.2** "Full Members" shall be the Leaders of participating teams engaged in events and activities organised by NatSKA. A Team Leader must be approved by the Board of Directors.

**A4.1.3** The Directors may from time to time admit any person, organisation or body as an additional member and may at their discretion remove any such person or body from the list of members.

**A4.2** Full membership shall be open to any school or youth group, recognised by NatSKA, provided that

**A4.2.2** the group agrees to abide by the rules, regulations and obligations of NatSKA (failure to do so may result in exclusion from NatSKA), and

**A4.2.3** on joining NatSKA or renewing membership the appropriate Membership Form (Form F01) is completed, and

**A4.2.5** It is required a Disclosure and Barring Service (DBS) check is carried out on all Team Leaders and assistant Team Leaders,

and recommended to carry out checks on all adult helpers. The costs of such checks are the responsibility of the Team however NatSKA may act as the requesting organisation in the case of new teams.

**A4.3** Under special circumstances a driver, whose licence has expired but who has competed on a regular basis in NatSKA events, may apply for an extension of his/her licence for a period of one calendar year in addition to the regulations stated in the NatSKA Handbook of that year. Such applications shall be made on behalf of the driver by the Team Leader and the Directors will consider the application on an individual basis.

**A4.4** Team Leaders are advised to check with their Local Authority, School, or Youth Association that parents and pupils who have left the school are covered by their mini-bus insurance policies, as practice in this area varies in different parts of the country.

#### **A4.7 Arbitration**

Where a full member or team member are experiencing difficulties within the team, either the team leader or team member can approach the Directors to act as arbitrators.

**A4.7.1** The scheme is an entirely voluntary system of dispute resolution: it will only apply if both parties have so agreed.

**A4.7.2** Any agreement to submit a dispute to arbitration must satisfy the following requirements:

**A4.7.2a)** The agreement must be in writing of an existing dispute.

**A4.7.2b)** The agreement must concern an existing dispute.

**A4.7.2c)** The agreement must not seek to alter or vary any part of NatSKA Handbook and Regulations.

**A4.7.2d)** The agreement must not seek to alter or vary any part of a team/club constitution.

Where an agreement fails to satisfy any one of these requirements no valid application to the scheme will have been made, and the parties will have to settle their dispute by other means.

**A4.7.3** Resolutions of disputes is intended to be confidential, informal, and relatively fast and cost efficient. Arbitral decisions (“Awards”) will be final and must be abided by both parties with very limited opportunities to appeal or otherwise challenge the result.

**A4.7.4** Appeals must be put to a postal vote of the full membership.

**A4.7.5** For the purpose of A4.7:

1. Full Member is as defined in A4.1.2

2. Team Member maybe either:

a) Pupil

b) Parent

c) Anyone associated with the team

**A4.8** Conduct of Members and their associates

**A4.8.1** NatSKA expects its Members and their associates, at all times to:

(i) Abide by the organisation's objects, rules and regulations.

(ii) Respect the decisions of event officials.

(iii) Treat all members, organisers and officials with respect.

(iv) Maintain the highest standards of behaviour.

(v) Always act in the best interests of NatSKA and not to bring it into disrepute.

(vi) Abide by the NatSKA policy relating to the use of Social Media

### **A5. Voting Rights**

**A5.1** Voting rights at the Annual General Meeting (AGM), Extraordinary General Meetings (EGM) and any other general meetings will be one vote per member school or youth group on production of the clubs membership card.

**A5.2** At an AGM or EGM members will be entitled to proxy votes as in A5.1. These votes must be sent in writing to the Secretary, to be received by the first post on the day before the meeting. Each vote must refer specifically to a proposal and may not be used to vote for or against any amendment which the meeting may put to that proposal, and may not be used to vote for or against a motion once that motion has been amended.

**A5.3** The Chairman of any meeting, in addition to his or her own vote as a member, shall also have a casting vote.

**A5.4** All Directors shall each have one vote.

**A5.5** Any duality of roles does not entitle the member to more than one vote, unless under A5.3.

## **A6. Subscriptions**

**A6.1** Subscriptions will become due from September every year and must be received by the Membership and Licensing Director by last post on the day before the AGM. Full membership will be £50 per annum. Subscriptions renewed on or after the AGM will be charged at £70 per annum per member. Membership will run from the date of one AGM to the date of the next AGM. Members who have not renewed their subscription by last post on the day before an AGM will lose their right to vote at that AGM and all other benefits of membership. The first year of membership is free of charge for new teams of new drivers.

## **A7. Records Officer**

**A7.1** If possible the Directors shall appoint a Records officer to build an archive of information and maintain it up to date.

## **A8. Annual General Meeting**

**A8.1** NatSKA shall in each year hold an Annual General Meeting (AGM), in addition to any other meetings in that year and shall specify the meeting as such in the notices calling it. Not more than 15 months shall elapse between the date of one AGM of NatSKA and that of the next. The AGM shall be held at such time and place as the Directors shall appoint. All General Meetings other than the AGM's shall be called Extraordinary General Meetings.

**A8.2** The Secretary shall give at least 21 days notice in writing of the AGM.

## **A9. Extraordinary General Meeting**

**A9.1** The Directors may, whenever they think fit, convene an Extraordinary General Meeting (EGM) and an EGM shall also be convened on the requisition of three or more voting members or in default may be convened by such requisitions as provided by Sections 303 and 304 of the Companies Act 2006. If, at any time, there are not

sufficient directors capable of acting to form a quorum, any Director, or any three voting members of the company, may convene an EGM in the same manner, as nearly as possible, as that in which meetings may be convened by the Directors.

**A9.2** This meeting is to be called within 21 days of the receipt in writing of the request.

## **A10. Directors and Committee Members Meetings**

**A10.1** The committee shall be the Directors and Committee Members of NatSKA, herewithin referred to as the "Committee".

**A10.2** At each meeting of the Committee one item on the agenda will be the discussion of proposals, from the membership for the amendment of the Operating Regulations, NatSKA Meeting Regulations, Kart Specifications or Kart Classes with a view to these being implemented or carried through to the next AGM.

## **A11. Quorum**

**A11.1** Twenty per cent (20%) of the voting membership of NatSKA shall constitute a quorum. At a General Meeting only paid up members shall be entitled to vote.

**A11.2** At any Committee meeting a quorum of 45% is required for a meeting to take place.

## **A12. Directors and Committee Members**

**A12.1** Directors shall be elected at either an AGM or EGM. Nominations must be made by a team leader not less than 14 days prior to the meeting, in writing and seconded by a different team.

**A12.2** The Directors shall be Chairman, Secretary, Treasurer, Technical Director, Membership and Licensing Director, Competition Secretary and Development Director.

**A12.3** The Chairman shall be elected for a period of three years, an incumbent Chairman having served the initial three-year period has the option to call an election of a new Chairman prior to an AGM within subsequent periods of office, all other

directors to relinquish their posts annually but will be eligible for re-election. Any uncontested application for a post within the committee will be accepted without vote.

**A12.4** Committee Members shall be Development Officer, Promotions Officer, Assistant Competition Secretary, and Schools Liaison Officer. By agreement of the Directors other nominations for officers may be accepted to assist the running of NatSKA.

**A12.5** Committee Members may be elected at the AGM or co-opted in to post with the agreement of the Directors at any time during the year.

**A12.6** Directors must attend 50% of all committee meetings held of which there must be no less than 2 in any 12 month period (in addition to the AGM).

**A12.7** Committee Members must attend 50% of all committee meetings held.

**A12.8** Should any report of activities which could bring NatSKA or Motorsport in general into disrepute be reported it is the responsibility of the committee to investigate these and make recommendations and/or to take sanctions as appropriate. This is to include reporting any events to Motorsport UK if it is felt necessary.

### **A13. Accounts**

**A13.1** The Accounts of NatSKA will be produced annually by a professional body for submission to Companies House and the AGM.

### **A14. National Licence Scheme**

There are 3 types of NatSKA Licence: Novice, Full Racing Licence and High Power Racing Licence

**A14.1 Novice Licence:** In order to obtain a Novice Licence the driver must be at least 8 years of age and, if before their 10<sup>th</sup> birthday are restricted to driving karts within the cadet classes 1 and 4 only, and fulfil the following requirements:

**A14.1.1** prior to the first meeting in which the driver wishes to take part the driver must apply to the Membership and Licensing Director for a Novice Licence, using form F03;

**A14.1.2** the driver must have completed the current Oral test.

**A14.1.3** The team leader shall send the application together with the appropriate fee, a passport size photograph with the driver's name printed clearly on the back and a stamped addressed envelope to the Membership and Licensing Director who will issue a Novice Licence with an additional record card on the back on which a record of all practice, race, and marshalling events and must be kept. The application and licence number shall be filed for future reference.

**A14.2 Full Racing Licence:** To upgrade from a Novice Licence to a Full Racing Licence the driver must fulfil all the following requirements in the correct order, evidence of which shall be recorded on the driver's record card:

**A14.2.1a** be observed to have driven competently in four practice sessions at four separate NatSKA race meetings by a suitably experienced team leader from another school or youth group who must complete the appropriate section on the record card. A suitable novice observer may be nominated by a team leader to assist with the role of signing novice licences. A signature will not be valid if obtained at a Race Meeting where the driver has received any penalty points on their licence.

**A14.2.1b** If a Motorsport UK Official notifies the NatSKA Licensing Director that a driver should be moved to a Full racing licence on grounds of safety, the Directors will review the notification and in conjunction with the Team Leader may choose to allow a driver to move directly from Novice practice to Back of Grid racing. The driver is still required to gain the relevant number of back of grid novice signatures to receive their Full race licence. The Motorsport UK Official must NOT be asked to observe a particular driver, doing so will lead to the Directors excluding any notifications for the given driver from their review.

**A14.2.1c** To be eligible for a Novice Observation Signature in a shared kart entry, the novice driver must (i) provide prior notification to the Observer as to which

sessions he/she is to be observed in, and (ii) must complete no less than two practice sessions.

**A14.2.1d** All requests for novice observation should be made at Team Leaders' briefing.

**A14.2.2** Only after gaining these four signatures, to be observed to have driven competently in two race sessions having started from the back of the grid at two further separate NatSKA race meetings by either the Motorsport UK Steward or the Motorsport UK Clerk of the Course. Only the Motorsport UK Steward or the Motorsport UK Clerk of the Course may complete the appropriate section of the record card. Record cards must be handed in to Race Control before practicing or racing starts.

**A14.2.3** On completion of the required signatures the driver must continue to start from the back of the grid for the remainder of the meeting.

**A14.2.4** Marshal competently during at least four practice or race sessions at NatSKA meetings;

**A14.2.4.2** A marshalling session should total a minimum of one hour and only one signature may be obtained per race meeting.

Upon completion of the requirements of A14.2 the team leader shall send an application for an upgrade to an existing novice licence together with a passport size photograph with the driver's name printed clearly on the back and a stamped addressed envelope to the Membership and Licensing Director who will issue a Full Licence. The application and licence number shall be filed for future reference.

**A14.3 High Power Licence:** To upgrade from a Full Racing Licence to a High Power Licence the driver must fulfil all the following requirements;

**A14.3.1** Have reached the minimum age for the class required.

**A14.3.2** Have completed at least 4 race meetings in classes 1, 4, 5, 10, 11, 12, or 14, after upgrading to a Full Racing Licence reduced to 2 race meetings when a driver is 14 years or older.

**A14.3.4** Drivers entering classes 7, 8, 13 or 15 are required to start racing from the rear of the grid until they have obtained four signatures from the Motorsport UK Steward on the Signature Card supplied with their upgraded licence, and that card returned to the Membership and Licensing Director. They are required to carry an additional yellow rear number plate on his/her kart with the letter "N" clearly displayed. Only one signature can be obtained at each NatSKA race meeting. Record cards must be handed in to Race Control before practicing or racing starts. A signature will not be valid if obtained at a Race Meeting where the driver has received any penalty points on their licence.

**A14.3.5** A High Power Licence permits the driver to race in all NatSKA classes.

#### **A14.4 Licence Exemptions**

**A14.4.1** A driver who holds and produces a non-novice Motorsport UK Karting Licence with their NatSKA application form is not required to complete the NatSKA Novice stage and can apply for a Full Racing Licence or High Power Racing Licence immediately.

In this instance the certification of competency outlined in regulation A14.2.2 must be carried out at the drivers' first race meeting, during practice, by the Clerk of the Course or his nominated observer and signed off by said observer before racing. The driver will be gridded at the back of the grid for the whole of their first meeting.

The requirement to comply with regulation A14.1.2 and A14.2.4 still need to apply however. Where a Motorsport UK driver applies for a licence exemption, they will be issued with a marshalling-only signature card, which on completion must be returned to the Licensing Director. Failure to return the card will result in the necessity to complete all stages of the high power upgrade.

**A14.4.2** A new driver to NatSKA, or an existing driver 14 years old or higher will be able to apply directly for a High Powered Novice Racing Licence providing that upon submission, they meet the minimum age requirement for the class to be entered and

give proof of having passed a Motorsport UK approved ARKS test. A driver must gain six High Power BOG signatures before being granted a full High Power Licence, existing Motorsport UK signatures can be counted towards the six.

A High Power signature card and marshalling signature card will be issued, which must be completed as per A14.3.4

**A14.5** Licences shall be valid as shown in Appendix B.

**A14.6** The charges for a Novice Licence, upgrade to a full licence, upgrade to a high power licence, renewal of a licence and temporary licences shall be set at the AGM. Any new charges shall be effective one month after they are set at the AGM. The charges are as noted in Appendix B.

**A14.7** It is the Team Leaders responsibility to apply for upgrading licences and returning signature cards as soon as possible. Grids for a Race Meeting will be generated using the status of a driver on the Driver Database at that time. Drivers will remain Back of Grid until signature cards are received by the Licensing Director. Urgent changes to the database should be notified by email together with attachments, to be followed by the original documents.

**A14.8** A licence will only be valid whilst the driver is a member of the school team or youth group named on the licence. The driver must reapply for a licence if he/she changes school or youth group.

**A14.9** The driver shall produce his/her licence at official scrutineering at a NatSKA event.

**A14.10** The team leader responsible shall ensure that applicants are competent and safe when driving, and that applications for upgrading to a full or high power licence are not made too early.

**A14.11** It is the responsibility of team leaders to ensure that licence photographs are up to date. If it is necessary to update a licence, send the old licence, a new photograph and a stamped self addressed envelope, along with the appropriate fee, to the Membership and Licensing Director for renewal.

## **A15. Medical Declaration**

**A15.1** Any applicant for a NatSKA Licence with a congenital abnormality of any limb, or amputation or with any other disability should first contact the NatSKA Directors who will be pleased to advise and help the applicant.

**A15.1.1** The following are regarded as being incompatible with fitness to race: Paraplegia, Hemiplegia, quadriplegia, epilepsy, myocardial infarction, myocardial ischemia, coronary artery by-pass surgery, coronary angioplasty, valvular disease of the heart or other abnormal condition whether operated on or not, and severe hypertension which has given rise to cardiopulmonary problems.

**A15.1.2** It is strongly recommended that asthmatics should wear an identity tag (ie bracelet or necklace) declaring that they are asthmatic and that they should inform the event's chief medical officer of their condition prior to competing.

**A15.1.3** When applying for a NatSKA licence all applicants are required to declare any physical disability.

**A15.1.4** Disabled drivers may be required to provide a note from his/her GP describing the applicant's disability and, if applicable, an opinion from any specialist who has been consulted. The cost of any such report shall be the responsibility of the applicant.

**A15.2** The above regulations are intended as a guide for applicants. It is the responsibility of the applicant to ensure that they are fit to hold a NatSKA licence.

## **A16. Expenses and Payment**

**A16.1** For any expenditure on behalf of NatSKA over £100 quotations shall be sought and submitted to the Treasurer for approval.

**A16.2** Payment of out of pocket expenses will only be made upon production of a receipt with the exception of petrol costs which shall be paid at a rate to be set by the Directors from time to time.

**A16.3** Payments due to NatSKA shall be paid within 28 days of the date of invoice/request. Failure to honour any payment may result in sanctions being taken against the debtor.

## Part B: NatSKA Kart Meetings

### B1. Generally

**B1.1** These regulations combine the requirements for all directors, committee members, organisers, competitors, and any person present at a kart meeting. By this means it is hoped that all concerned with karting will obtain a clear picture of the activity and organisers will find their tasks simplified.

**B1.2** No meeting may take place without due reference to the relevant, current Road traffic Act.

**B1.3** All NatSKA kart meetings held at licensed Motorsport UK circuits shall have the appropriate Motorsport UK Permit and follow the rules to run the meeting under such permit.

**B1.4** At any NatSKA kart meeting, it may be possible to run a NatSKA Tyro event. This Tyro event will be open to any non-NatSKA licensed persons over the age of 18, who are nominated by an appropriate Team Leader. This will primarily be aimed at an introduction to driving a kart and will require the specific instruction and briefing of the driver prior to the event. The briefing will enable the driver to be the holder of a NatSKA Tyro Licence for the duration of that Tyro event. The only classes that will be acceptable for the NatSKA Tyro event will be karts in classes 5, 10, 11, 12 and 14. The fee for a NatSKA Tyro Licence will be set at £5 per NatSKA Tyro event.

All other regulations to run a NatSKA Tyro event must follow Motorsport UK regulations as per the current Motorsport UK British Motorsports Yearbook (Competitors and Officials) and the current version of Motorsport UK Club Organisers Guidelines for Tyro events. At no time can a NatSKA Tyro event be used for a signature to upgrade any form of licence.

**B1.5** At any NatSKA meeting it may be possible to run guest classes who will run within the same timetable as the main NatSKA event, but will not have any bearing on the results or proceedings of the main event. These guest classes will be members

of an officially Motorsport UK recognised club, and hold licences as prescribed by their membership regulations. Details of such guest classes and the requirements for taking part will be officially notified in the Supplemental Regulations and/or Final Instructions. For any heats that the guest karts take part in all driving and licence regulations, including but not limited to penalties, will be taken from the regulation of their own governing motorsports body and those will take precedence over any such regulations in this handbook and regulations. The guest classes will only be permitted to use karts that are in their officially recognised motorsports association regulations, the exact details of which will also be notified in the Supplemental Regulations and/or Final Instructions.

### B1.6 Race Entries

**B1.6.1** Teams need to have their entries, withdrawals, amendments and payments with the Entries Co-ordinator in accordance with the deadlines specified in the Final Instructions for the relevant meeting. Entries must be done online on the Timing System. Late entries, late amendments or late payments will result in the relevant driver being run off the back of the grid. Entries are on a first come first served basis. When the grids are full, karts will be placed on a waiting list. Parental consent forms for all drivers are required to be lodged in race control during signing on.

**B1.6.2** It is the Team Leader's responsibility to submit a single payment to NatSKA on behalf of the whole team.

**B1.7** The running of generators in the paddock is prohibited between the hours of 2300 and 0700.

**B1.8** The riding of bicycles and scooters, and the driving of motor vehicles by persons not authorised under the RTA, is prohibited in the paddock.

### B2. Insurance

**B2.1** All schools and youth groups must consult their controlling authority with regard to insurance.

**B2.2** All teams should have in place third party insurance cover as required by their school, Local Education Authority or Governing Body.

**B2.3** All students / pupils / youth group members attending NatSKA meetings shall be covered by Personal Accident Insurance for the duration of all meetings. It is strongly recommended that cover be put in place for travel days outside of the event duration. Adult team members / helpers / leaders may also obtain cover at their own discretion.

**B2.4** Team leaders are urged to ensure that all safety precautions are observed with regard to driver instruction, kart construction, track procedure and track layout.

**B2.5** Team leaders must gain the permission of their sanctioning body before carrying out any karting activities.

### **B3. Track Safety and Inspection**

**B3.1** The entire circuit shall be given a safety inspection, before the drivers' briefing, and at any point during the meeting when, where the track conditions have changed, by the Motorsport UK Clerk of the Course, Club Stewards, and the Motorsport UK Steward if present. The inspection shall be performed specifically to check the safe condition of the circuit, e.g. tyre barriers in place and intact, stones/metalwork/other debris not on track, condition of run off areas, provision of marshalling points, notification of other general hazards.

### **B4. Equipment**

**B4.1** The following signalling equipment shall be available at all events:

**B4.1.1** for the Clerk of the Course: red flag, black flag with orange disk in centre, black and white diagonal flag, and black flag, along with a number board.

**B4.1.2** for each Flag Marshal Post: red, green, yellow, white, blue, black and yellow quartered, and red and yellow striped flags.

**B4.1.3** for the Starter, starting equipment, standard marshal post flags plus black and white chequered, black with orange disc, black, black and white diagonal, green with a yellow chevron false start, national flags,

number board and also a board inscribed "Last Lap";

**B4.1.4** fire extinguishers (minimum 2kg dry powder, with annual certification that they are in working order) shall be positioned as follows: one at the start line; two in the grid area; one in parc-ferme in clearly visible position; and others at agreed points on the circuit;

**B4.1.5** one blackboard and chalk or a suitable means of displaying notices to drivers;

**B4.1.6** each team must carry at least one 2kg dry powder fire extinguisher, per 5 karts, that is in working order clearly visible and available within their pit area. Each fire extinguisher must be certified to be working order and carry details of last service date and the next due service date.

### **B5. Officials**

**B5.1** The officials identified in regulation B5.2 shall be appointed and briefed prior to the meeting. They shall be present throughout the event and be responsible for carrying out the duties defined. No chief official shall be under 16 years of age, and these officials shall, where possible, be taken from people who have previous experience of that post at NatSKA meetings. In certain circumstances one official may do more than one job (this does not apply to the Chief Clerk of the Course or the Chief Scrutineer). All officials named in the Supplementary Regulations (SR's) or Final Instructions are to wear badges, to be provided by the Secretary of the meeting, stating name and function at all meetings. Only those officials are to act in the functional capacity stated unless the Chief Clerk of the Course co-opts, and announces or publishes to the meeting, other suitably qualified personnel. Team leaders must wear their identifying badges at all times during a meeting. No individual may be entered as a competitor in an event for which they have been nominated as an official in the regulations or program for that event.

**B5.1.2** Should the organisers of the meeting find that a designated Motorsport UK official is not adhering to the rules as per the



NatSKA handbook and regulations, they may create a delegation to the Motorsport UK steward with the aim to resolve it.

## **B5.2 Declaration of Officials**

### **B5.2.1 Stewards**

**B5.2.1.1** At least two club stewards shall be appointed by the organisers to be responsible for the regulations and ensuring that the officials are performing their duties properly. If appropriate they shall be prepared to be part of a hearing, chaired by the Motorsport UK Steward (if present), to consider appeals.

**B5.2.1.2** Where possible the stewards should be selected from persons independent of participating teams.

### **B5.2.2 Secretary of the Meeting**

**B5.2.2.1** Shall be in charge of all paperwork and responsible for all equipment and materials being available.

**B5.2.2.2** Shall be responsible for receiving any protests or appeals from team leaders, noting time of receipt, and ensuring that all protests are passed on to the Chief Clerk of the Course, and all appeals to the Stewards of the meeting, as rapidly as possible.

### **B5.2.3 Clerk of the Course**

**B5.2.3.1** The Clerk of the Course is the first judicial body. The Clerk and their deputy(s) shall have the power to impose penalties. They are responsible for the conduct of the meeting and liaising with other officials as is appropriate. Current Motorsport UK permits require that a Motorsport UK licensed Clerk of the Course be appointed to this post, who will also be responsible for:

**B5.2.3.1i** in conjunction with Motorsport UK Steward and Club Steward deciding on the abandonment or postponing of a meeting in the event of unforeseen circumstances; and

**B5.2.3.1ii** ensuring that no unauthorised running of karts takes place; and

**B5.2.3.1iii** declaring a meeting wet, in which case only karts running on wet tyres, with a minimum of 2 mm tread depth over the entire contact area at the start of a heat, shall be allowed to participate (no hand cutting of

tyres is permitted). A definition of a wet tyre is given in regulation D2.7.

**B5.2.3.2** It is the responsibility of the Chief Clerk of the Course to ensure that the Motorsport UK Steward is furnished with all relevant and required paperwork.

### **B5.2.4 Chief Medical Officer**

**B5.2.4.1** Shall be appointed in accordance with Motorsport UK Permit requirements.

### **B5.2.5 Chief Scrutineer**

**B5.2.5.1** Shall be responsible, with the help of NatSKA recognised gold card scrutineers, for:

**B5.2.5.1i** ensuring that all karts are fit to be driven and comply with current NatSKA specifications; and

**B5.2.5.1ii** ensuring that all drivers have suitable clothing and, at all race meetings, a valid NatSKA racing licence; and

**B5.2.5.1iii** inspecting and checking specification and identity of all helmets; and

**B5.2.5.1iv** re-inspecting any kart and/or helmet involved in an accident; and

**B5.2.5.1v** enforcing current noise limits.

**B5.2.5.2** Current Motorsport UK Permits require a Motorsport UK licensed Scrutineer to be appointed to this position. They may be supported by NatSKA "Gold Card" Scrutineers.

**B5.2.5.3** It shall be the responsibility of the Team Leader to ensure that all Gold Card scrutineers within a team have access to copies of these regulations together with any updates, addenda, etc., which may be issued during the course of a season.

**B5.2.5.4** Each team must provide a Gold Card scrutineer for every meeting, who must attend a briefing with the Chief Scrutineer prior to commencement of the safety scrutineering, unless they are new members of NatSKA in which case they must provide a Gold Card scrutineer at any meeting they enter starting twelve months after the date of them having first joined NatSKA. No NatSKA gold card holding scrutineer may carry out any official scrutineering activity on any kart

or driver entered by the team to which they are attached or affiliated.

**B5.2.5.5** All measuring equipment used by scrutineers must be measured against a test piece held by the NatSKA Committee that will be available at every NatSKA race meeting in the absence of Motorsport UK equipment.

### **B5.2.6 Chief Timekeeper**

**B5.2.6.1** Shall record times taken if required.

**B5.2.6.2** Shall assist the starter in recording any break of formation for the starting of events.

### **B5.2.7 Chief Lapscorer**

**B5.2.7.1** Shall keep a record of the laps covered and act as finishing judge. Each team with seven or more over 18 years old shall provide one suitable lap scorer to the team organising the meetings. Organising team to inform on day when and where required. Refer to scoring system in Appendix N for details.

### **B5.2.8 Chief Course Marshal**

**B5.2.8.1** Shall be responsible for:

**B5.2.8.1i** ensuring that the track surface and protective works are maintained in good order throughout the meeting; and

**B5.2.8.1ii** ensuring that fire fighting equipment is readily available and correctly sited; and

**B5.2.8.1iii** ensuring that track cleaning equipment is sited at suitable points; and

**B5.2.8.1iv** supervising the removal of any kart which may have stopped on or adjacent to the track; and

**B5.2.8.1v** seeing that no unauthorised person or persons come within the area of the track.

### **B5.2.9 Paddock Marshall**

**B5.2.9.1** Shall assemble drivers in grid order prior to entering the track, ensure that no vehicle goes out onto the track until it has been approved by the Scrutineer and exclude from the grid any unauthorised person or persons who do not have the appropriate grid pass available for inspection.

### **B5.2.10 Starter**

**B5.2.10.1** Shall be responsible for starting and finishing events and communicating warnings and other on track penalties to drivers. The starter will be used to determine the correct formation for starting a heat. The starter shall be over 18 years of age and may have a maximum of two assistants, over 16 years of age. The starter shall be a judge of fact. In the event that the start line position also doubles as a marshal post a maximum of 2 marshals will man the post, these marshals shall be over 16 years of age.

### **B5.2.11 Chief Observer**

**B5.2.11.1** If a suitably experienced and qualified person is available, i.e. a British Motorsports Marshals Club (BMMC) Kart Observer or equivalent, a Chief Observer may be appointed to observe driving standards.

### **B5.2.12 Flag Marshals**

**B5.2.12.1** Flag Marshals may be recruited from those under 16 years of age who have shown responsibility. They must report and be responsible to the Chief Course Marshal. A maximum of three marshals shall be permitted on each marshal post if the marshal posts at a particular circuit are of sufficient size. Marshals shall remain in their posts at all times whilst karts are on the circuit. An experienced marshal is a person who has completed the marshalling requirements of the National Licence Scheme to a standard whereby he/she is eligible to hold a full NatSKA Racing Licence.

**B5.2.12.2** It is recommended that each team nominate one person (minimum 18 years of age) to co-ordinate marshalling on behalf of their team and be responsible for the training of parents and students within their team.

### **B5.2.13 Eligibility Scrutineer**

If detailed checks of an engine are to take place then an Eligibility Scrutineer needs to be appointed. If present the NatSKA Technical Director may also be able to assist in performing detailed examination of any kart components to ensure they meet the specifications as laid out in the regulations. If

an Eligibility Scrutineer is not present then the Chief Scrutineer may make reasonable measurements with known equipment to check kart components against their regulations.

## **B6. Rights and Duties of Organisers**

**B6.1** The organisers shall be entitled to:

**B6.1.1** refuse any entry; and

**B6.1.2** exclude any driver or kart appearing on examination to be ineligible for the event on recommendation from the Chief Scrutineer or Chief Clerk of the Course; and

**B6.1.3** publish mandatory instructions, all race meetings shall have Final Instructions and entry details published before the opening date for entries. Any changes to the programme or Final Instructions must be communicated to all members in writing, and

**B6.1.4** publish Supplementary Regulations (SR's) at the beginning of each season showing general regulations for the meetings to be held that season; and

**B6.1.5** communicate any changes to the SR's to all members and shall ensure this is performed subject to Motorsport UK regulation B8.4 as noted in Appendix I; and

**B6.1.6** change the order in which events are run at a meeting.

**B6.1.7** Respond to any report of bringing NatSKA or Motorsport in general into disrepute. This should be referred to the Chief Clerk of the Course on the day and a written report of the event and any proceedings passed on to the Directors for the consideration of further action.

**B6.2** The organisers shall be responsible for:

**B6.2.1** compliance with these regulations; and

**B6.2.2** ensuring that all karts are fitted with effective silencers and all local environmental requirements are met; and

**B6.2.3** ensuring that no unauthorised running of karts takes place before, during or after the meeting.

**B6.3** The Organisers of any NatSKA meeting shall sign a declaration (Form F12) stating that the meeting shall be organised and run

in accordance with the current NatSKA Handbook and Regulations without exception.

## **B7. Signals**

**B7.1** Signals shall be displayed to drivers by means of flags, boards or lights. None of the signals in regulation B7.3 shall be used for any other purpose and no signal shall be given which might be mistaken for one of these official signals.

**B7.2** Competitors who fail to obey these signals shall be penalised.

**B7.3** The official signals are:

**B7.3.1** Red/Green lights or National flag: Start

Red and Green lights are mandatory for the starting signal. The National Flag should only be used as a starting signal if the lights fail.

- Rolling start – start at the moment flag is raised.
- Standing start – start at the moment the flag is dropped.

**B7.3.2** A Green Flag with Yellow chevron – false start, proceed on further rolling lap in grid formation.

**B7.3.3** Blue flag – Stationary: Another competitor is following close behind.

**B7.3.4** Blue flag – Waved: Another competitor is trying to overtake.

**B7.3.5** White flag: A service vehicle or slow moving kart is on the circuit. The white flag will be waved to indicate the sector of the track that the slow moving vehicle is in, and held stationary whilst the vehicle is in the next sector.

**B7.3.6** Yellow flag – Stationary: Danger, slow down sufficiently to ensure that full control of the vehicle can be retained. No overtaking.

**B7.3.7** Yellow flag – Waved: Great danger. Slow down considerably. Be prepared to suddenly change from the projected racing line, or take other evasive action including stopping if necessary. No overtaking.

**B7.3.8** Yellow flag with Red Stripes – Stationary: Slippery surface ahead.

**B7.3.9** Yellow flag with Red Stripes – Waved: Slippery surface imminent.

**B7.3.10** Green flag: All clear, at the end of a danger area controlled by yellow flags. Also used to signal the start of a formation lap and shown at all posts during first lap of each practice session and during the formation lap.

**B7.3.11** Red flag: Immediately cease driving at racing speed and proceed slowly, without overtaking, and with maximum caution to pits or start line obeying marshal's instructions, and being prepared to stop should the track be blocked.

**B7.3.12** Black flag with Orange disc displayed with the competitor's number: Notification of apparent mechanical failure or of a fire which might not be obvious to the driver. The kart concerned must call at its pit for repairs on the next lap.

**B7.3.13** Black and White Rectangular flag split diagonally and displayed with the competitor's number: A warning, to the driver that their behaviour is suspect and that they may be Black-flagged on further reports.

**B7.3.14** Black flag displayed with the competitor's number: The driver must stop at their pit within one lap of receiving the signal and report to the Clerk of the Course. A penalty of exclusion may be enforced by display of the Black flag.

**B7.3.15** Black and White Chequered flag: End of Race or Practice, cease driving at racing speed and proceed slowly, without overtaking and with caution to the pits.

**B7.3.16** Yellow/Black Quartered flag: This flag may be introduced by the Clerk of the Course following a report from an Observer. The flag will first be displayed at the start/finish line and then in trackwise order at all flag posts. On passing the flag at the start/finish line, the Race leader must slow down sufficiently to a steady pace as used on a rolling start and all competing Karts must line up in order behind the Race leader who will act as the pace setter. No overtaking is permitted. The field will remain in close formation, at reduced speed, for as long as it takes to clear the obstruction or remove the hazard, whatever its nature. Competitors who fail to slow down sufficiently or who overtake under the Yellow/Black flag,

thereby gaining advantage, may be excluded or otherwise penalised. When the Clerk of the Course is satisfied that the track is clear, or the problem resolved, the Race will be resumed with a Green Flag at the start/finish line and the simultaneous withdrawal of all Yellow/Black flags around the circuit.

**B7.4** At an incident where the track is obstructed, or marshals are working at the trackside, the following signals will be used:

- A Stationary Yellow at the post before a Waved Yellow.
- A Waved Yellow flag at the post immediately preceding the incident. N.B. In very serious cases, this flag may be supplemented by an additional waved yellow flag at a preceding post.
- A Stationary Green flag at the post immediately after the incident.
- If the incident is well off the track and marshals are not working at the trackside, the incident may be indicated by a stationary yellow flag, followed by a stationary green flag.

**B7.5** It shall be an offence to overtake or fail to slow down from wherever yellow flags are displayed until the green flag or next marshal post not displaying the yellow flag is passed.

**B7.6** The black flag and black and yellow quartered must be used only by, or on the instructions of, the Chief Clerk of the Course.

**B7.7** It is an offence to break formation before crossing the start/finish line and before the start of a race is signalled when participating in a rolling start.

**B7.8** The black flag with an orange disc in the centre must only be used by or on the instruction of a Motorsport UK Scrutineer or a Clerk of the Course.

## **B8. Licences**

**B8.1** All competitors must be holders of a current full NatSKA racing licence or NatSKA novice licence and shall bring their licence to all meetings for inspection. Any driver not bringing their NatSKA racing licence to a race meeting / scrutineering is required to pay for a temporary licence (valid for that

meeting only) from race control. The cost of a temporary licence is £5.00 per meeting.

## **B9. Eligibility**

**B9.1** Chassis and engines – any kart entered to take part in a NatSKA class within a NatSKA meeting must comply with NatSKA's Kart Specifications and be in sound mechanical condition.

**B9.2** All karts must be made available for inspection by the Chief Scrutineer at the request of the organisers, the Chief Scrutineer, or the Chief Clerk of the Course, at any time during the meeting. Any inspection may include dismantling the karts engine or engines to any extent deemed necessary by the officials of the meeting. The Scrutineer may at his discretion seal the engine and/or associated parts and carry out such inspection after the last heat or at the end of the meeting in which it is used or at a later date by consent of interested parties.

Where an issue arises relating to the eligibility of a NatSKA entered kart, the definitive decision remains, in the first instance, with the NatSKA Technical Director.

**B9.3** All karts and equipment shall be presented for inspection in a clean condition.

**B9.4** Any kart which, after the approval of the scrutineer, has been dismantled or modified in a manner which may affect its safety, or which has been involved in an accident, shall be represented for the approval of the scrutineer.

**B9.5** Drivers must complete a minimum of three practice laps before competing in any event at racing speed.

**B9.5.2** Drivers are expressly forbidden to practice or use the circuit in any type of kart from the Monday directly prior to an event, unless it is an officially-endorsed NatSKA practice day. Any driver reported or deemed to have done so may be excluded from that meeting.

**B9.5.3** A driver shall not take time off school to participate in a NatSKA event without the prior written approval of their school, which should be provided to the Secretary of the Meeting upon request.

**B9.6** Before any kart proceeds on the track a check may be made that it has been approved by the scrutineer.

**B9.7** The tools used by a Scrutineer to check for eligibility to the regulations should be in good condition and where appropriate certified as to their accuracy. No examination should be started if the examining Scrutineer is not capable of accurately measuring the component in question. If the required tools are not present on the day, or the required skill set is not available, the questioned parts should be sealed and sent to the Technical Director.

**B9.8** At any time, any part of kart may be sealed by the Chief Scrutineer. Once this part has been sealed it may not be removed or modified without the prior consent of the Chief Scrutineer. Replacement of sealed parts will normally be requested to take place in the scrutineering compound and any replacement will be sealed prior to the kart leaving.

**B9.9** Any kart may be used with a maximum number of engines, chassis or other components. It is the responsibility of the Team to ensure that all engines and chassis be presented to scrutineering prior to the event taking place. The maximum number of Chassis that can be used shall be 1. Another chassis may only be used if the previously-scrutineered chassis is deemed to be irreparable by the Chief Scrutineer and only applies to the bare chassis. The maximum number of engines shall be 5.

**B9.10** At any time the Eligibility Scrutineer /Chief Scrutineer may examine any NatSKA sealed component. If this component is found to be ineligible, that kart may be excluded from all heats that it has competed in with that sealed component. Any driver or team required to strip down their engine for an eligibility check must be prepared to strip down at the same time all engines entered on the Scrutineering Form.

**B9.11** All karts and engines must conform to the information appearing on Scrutineering Forms, which must be signed by the driver and the Scrutineer or NatSKA Gold Card Holder. All scrutineering stickers/seals

provided must be attached to the kart and helmet and be clearly visible.

**B9.12** The scales and/or check weights provided for competitors use are to be deemed correct on the day.

## **B10. Drivers**

**B10.1** Only persons who are, at the time of the event, eligible for a NatSKA licence and are accompanied by a nominated team leader of the school or youth group of which they are a member are eligible to enter. If the nominated team leader cannot be present at an event, then written permission is needed from the Head Teacher or recognised controlling body, authorising an alternative team leader to be responsible for the team and signing the scrutineering sheets and parental consent forms that must be brought to an event and handed to the Secretary of the Meeting before the team can race.

**B10.1.1** Under special circumstances it may be permitted for drivers who hold other approved licences from recognised motorsports organisations to take part in events separate to the main NatSKA event but held at the same time.

**B10.2** Teams must have a current Medical Data Form for each of their drivers at the meeting, which must be available in the event of an accident. The only acceptable is Form F07 contained in this document.

**B10.3** Any driver at the National Sprint Championship must have, during the preceding twelve months

- For low power classes, raced in at least three low power NatSKA race meetings, of which two must be for the class in which they are entered;
- In low power classes only, a driver who has recently completed the upgrading of their Novice licence to a full race licence but has only entered two Back of Grid race meetings, is permitted to enter the National Sprint Championship in that same low power class but from the Back of Grid.
- For High Power Classes, raced in the class for which they are entered at a

minimum of four NatSKA approved race meetings.

For avoidance of doubt, "raced" means having taken the start in at least one heat during the meeting.

The FOUR meetings where a driver is racing from the back of the grid as part of the High Power Licence requirements may be counted towards the minimum meetings requirements.

**B10.3.1** Any engine used at the National sprint Championship meeting must have been used by an eligible driver at a minimum of three NatSKA approved race meetings during the preceding twelve months or be included in the list of engines deemed eligible for the previous National Sprint Championship meeting. Once an engine has been used in this way it will be added to the list of engines eligible for future National Sprint Championship meetings. Exceptionally where a driver cannot reasonably comply with this requirement (for example where a "blown" engine has been necessarily replaced) a formal request with supporting evidence should be made to the Directors who, at their absolute discretion, may elect to grant a waiver.

**B10.3.2** The National Sprint Championship does not count towards the following year's Nationals eligibility.

**B10.4** All persons present shall attend the safety briefing prior to the commencement of practice or race sessions. It shall be an offence not to attend the safety briefing. The penalty for drivers not attending the safety briefing shall be on the first offence a £10 fine levied on the driver concerned and upon the second and subsequent offences a £10 fine and endorsement of the licence of the driver concerned.

**B10.5** It shall be the responsibility of the team leader to properly notify the organisers of the meeting of the status of those drivers who are newly entering classes 7, 8, or 15 from a less powerful class when submitting their entry. For the purposes of this regulation classes 7 and 8 are deemed to be of equal performance, whilst Class 15 is the highest class.

**B10.6** The following classes are deemed as acceptable for use by Novices when gaining their NatSKA licence: 1, 5, 10, 11, and 14.

## B11. Helmets and Clothing

### B11.1 Helmets

**B11.1.1** Drivers shall wear, whilst driving, a crash helmet which conforms to the standards noted below. Visor and complete gloves (of abrasive resistant material and not open backed or mitts) must also be worn when driving.

Only helmets complying with the following standards are acceptable:

FIA 8860-2010 (Not valid after 31.12.28)

FIA 8859-2015

SNELL SA2010 (Not valid after 31.12.23)

SNELL SA2015 (Not valid after 31.12.26)

SNELL SAH2010 (Not valid after 31.12.23)

SNELL SA2020

SNELL K2010 (Not valid after 31.12.23)

SNELL K2015

SNELL – FIA CMR2007

SNELL – FIA CMS2007

SNELL – FIA CMS2016

SNELL – FIA CMR2016

All crash helmets shall carry a current Motorsport UK approval sticker.

All drivers under the age of 15 are required to wear the Snell-FIA CMR2007 or CMS 2007 or CMR2016 or CMS 2016 standard youth helmet.

Note: The European Standard E22 is NOT acceptable.

**B11.1.2** The user must ensure that the helmet is to a standard currently specified, that it fits properly, is secured properly and that it is in acceptable condition.

**B11.1.3** Only one piece shell full face helmets are permitted.

**B11.1.4** A visor must be worn at all times during training, practice and competing, goggles are not permitted. Recommended visor standard: (minimum) BS4110, BS4110:1999, BS EN 1938 or European Standard 89/686/EEC. Visors must be clear or neutral density filters. "Whirley" visors are acceptable when fitted on top of normal

visors, but holes must not be cut in normal visors.

**B11.2** In all classes the minimum protective clothing requirements shall be a currently homologated CIK or Motorsport UK approved suit. The latest Motorsport UK homologated suits are as here, or listed in the current Motorsport UK Yearbook.

Only suits bearing one of the below labels are acceptable as CIK homologated

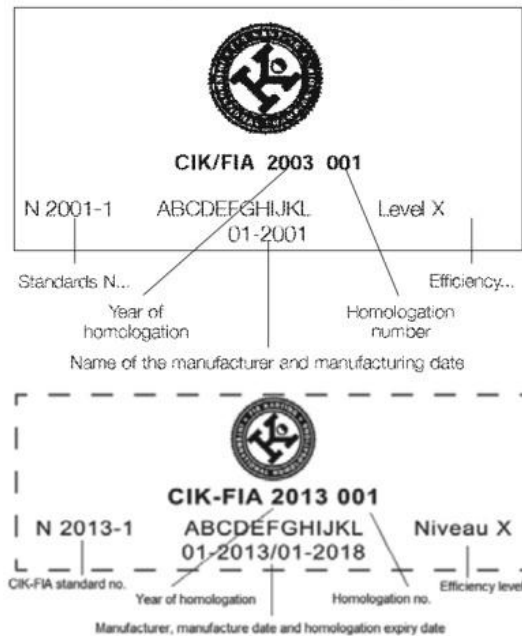

**B11.3** All helmets, suits, gloves and boots must be presented as separate items for scrutineering at all meetings, and be identified as acceptable for the duration of that meeting. Only those items, which have been scrutineered, may be worn at that meeting. Any helmet being failed at scrutineering will be impounded and returned directly to the Team Leader at the end of the meeting. A record of helmets that have been rejected by the scrutineers will be kept.

**B11.4** All drivers must wear footwear that provides adequate cover and protection to the ankles. It is recommended that Kart racing boots are worn. High or stack heeled boots are not permitted.

**B11.5** All drivers shall present themselves at the designated section(s) of scrutineering with the NatSKA approved driving suit (worn), footwear, helmet and gloves they intend to wear whilst driving.

**B11.6** It is strongly recommended that in all classes all drivers should wear a neck support and rib protectors to reduce the risk of injuries.

## **B12. Drivers' Conduct**

**B12.1** All persons shall conduct themselves in an orderly manner. Any failure to obey official instructions or any breach of these regulations shall render the driver and/or team liable to penalty. Abusive language or behaviour, physical assault or the threat of physical assault will not be tolerated and any such breach will render the driver and/or team liable to severe penalty, as set out in Appendix A.

**B12.1.1** Any driver considered as possibly unfit by reason of health, consumption of alcohol or prohibited substances shall be excluded from the meeting. Where applicable, an Offence Code A penalty shall be applied. The Chief Medical Officer will be the Judge of Fact in this regard.

**B12.2** There shall be no wild or disorderly driving. No kart may be driven other than in properly authorised areas.

**B12.3** The rule of the track shall be "the responsibility for overtaking rests with the driver overtaking".

**B12.4** In no circumstances may a kart be driven or pushed in any direction except the direction of racing.

**B12.5** Any driver stopping on the track or its verges should move to a position of safety and only if it is safe to do so, push his or her kart to a position of safety. They shall remain there until an official gives permission to move. In the event of a kart being disabled, the driver must be able to remove his/her own kart from the circuit; except assisted drivers. Drivers MAY be asked to demonstrate this ability to an appointed official before being allowed to race.

**B12.6** Any driver leaving the track more than twice in any one heat, whatever the reason, may be excluded from the race. Where a driver consistently drives with a wheel off the track or leaves the circuit, this may be deemed as gaining an unfair advantage.

**B12.7** Any driver attempting to rejoin the circuit as the consequence of a racing incident must do so at the nearest possible point compatible with safety, and gain no advantage as a result of that action.

**B12.8** Manoeuvres liable to hinder or endanger other drivers, such as premature direction changes on a straight, or any other abnormal changes of direction, may leave the driver facing penalties.

**B12.9** If there is a pit area, it shall be entered and left only by the correct routes. No kart shall be driven in the pit area and no kart shall enter the circuit without the permission of the paddock marshal.

**B12.10** Refuelling whilst competing in a heat or final is forbidden, unless permitted by Supplementary Regulations or Final Instructions in which case a refuelling area shall be designated with at least two fire extinguishers provided (minimum 2KG dry powder with annual certification that they are in working order). It is expressly forbidden to refuel karts on the track or dummy grid. Drivers must not be in the kart and the engine must be switched off during refuelling. A person over the age of 18 must be closely supervising the refuelling area.

**B12.11** Whenever karts are fuelled the position of fire extinguishers shall be noted. The engine must not be running and the driver must not be in the kart. No container holding more than five gallons of petrol shall be allowed in the paddock and only containers designed for the storage of petrol shall be used for this purpose.

**B12.12** All karts must leave the grid in a safe manner, at slow speed, so as not to endanger the pushers of other karts.

**B12.13** After receiving the end of competition (or practice) signal each driver shall continue slowly, without overtaking and with caution to the parc-ferme entrance.

**B12.14** Drivers shall raise an arm and move off the racing line when slowing or leaving the circuit.

**B12.15** Drivers shall be aware of other drivers when driving.



**B12.16a)** Once any part of a driver's body has touched the track surface then that driver may not continue in that heat.

**B12.16b)** No kart engine may be restarted in a heat or final, except:

**B12.16b)i** karts in gearbox classes, which may be restarted if they stall on the start line when carrying out a standing start.

**B12.16b)ii** karts in a novice event may be restarted by a signed on team leader or gold card holder or a signed-on official.

**B12.16b)iii** karts in an enduro event may be restarted by a signed on team leader or gold card holder or a signed- on official.

**B12.16b)iv** All Karts may be restarted after racing has finished in any one race or practice to speed the recovery of a still road-worthy kart to parc ferme. The restarting may only be performed by a signed on team leader, gold card holder, or a signed-on official.

**B12.16b)v** Karts fitted with on-board, driver operated electrical, starting system ARE allowed to restart if safe to do so, providing that no part of the driver has touched the floor.

**B12.16c)** A heat starts once the kart has passed the official start line as indicated by the starter's signal, from this point onwards any kart not taking the chequered flag is classified as a DNF. A kart which is not under its own power once passed the official start line will be classified as a DNS.

**B12.17** No Kart engine may be run on the dummy grid or surrounding paddock unless the driver is seated in the kart wearing the appropriate racing clothing including a helmet.

**B12.18** Kart engines shall not be run whilst the kart is on a kart stand or trolley unless both front wheels are in contact with the ground when properly attached to the kart and the kart is in a condition to be safely driven in a heat.

**B12.19** When attempting to start a kart engine, the driver must remain seated in a normal racing position within the kart at all times.

**B12.20** No kart engines may be started until after drivers' briefing or such time as advised by the organisers.

**B12.21** Driving karts anywhere in the pits or anywhere surrounding the circuit is prohibited.

## **B13. Race Procedure**

### **B13.1 Notice**

The attention of all persons attending a meeting, including officials, shall be drawn to the following notice:

**Warning to the public:**  
 Motor Sport can be Dangerous!  
 Despite the organisers taking all reasonable precautions, unavoidable accidents can happen. In respect of these, you are present at your own risk.

**B13.2** The number practising at any time shall not exceed the maximum permitted on the track for a race. Adequate practice periods must be allotted to all classes which must include sufficient time for competitors requiring observation to be seen. Where possible novice and experienced drivers should be allocated separate sessions.

**B13.3** At no time shall gearbox and non-gearbox classes practice or race together. Any gearbox karts taking part in heats with direct drive karts must have their gear change mechanism disabled and secured. It shall be an offence to change gear whilst competing with direct drive karts and the driver committing said offence shall be excluded from the heat, further penalties shall be at the discretion of the Clerk of the Course. However, due regard must be paid to driver experience and the relative speed of the karts if different classes are on the track at any one time during practice or racing.

**B13.4** The course or its features or markings may only be changed between the last practice period and the event itself in exceptional circumstances. Should it be necessary to make any change following the scheduled practice an additional period of practice must be arranged.

**B13.5** The starting order in which the Karts shall be arranged will be determined by:

- a) Ballot
- b) Lap times recorded in practice
- c) Order of receipt of entry
- d) Finishing order of a preceding race
- e) As defined in SRs

In all races where the grid position is determined by (a), (c) or (e), novice racing drivers must occupy the rearmost grid positions.

**B13.6** The Pole position shall be on the side of the track that is on the inside of the first corner after the start, or, as defined on the track licence.

### **B13.7 Grids and Race Start.**

**B13.7.1** The Grid is to be closed 3 minutes plus final lap before the end of the previous race, or 3 minutes prior to the end of any break or the start of the first heat. Once the grid is closed any arrivals will start from the back of the grid. Any driver moved from their grid slot to the back of the grid because of their late arrival must not attempt to regain their allocated grid slot on the rolling lap.

**B13.7.2** When the Starter is ready for a race, they must signal by raising a Green Flag. A Marshal will then raise a Green Flag which will be the signal for the Karts to be released on to the circuit. After the marshal has lowered the Green Flag, the entrance to the track will be closed and no further karts will be allowed to join the track.

Once the signal to start the race has been given, karts may not stop, be it intentionally or unintentionally, and make repairs or adjustments. However, they may return to the pits, or a designated maintenance area, to undergo repairs or changes. During a NatSKA Enduro event, the supplemental regulations and/or final instructions may indicate the place of driver change, and areas of repair or refuelling.

**B13.7.3** Except where B13.7.4 and B13.7.5 applies, no adjustments other than to tyre pressures or those capable of being performed with fingers only, will be permitted to karts on the dummy grid. (Tools will be

limited to use of a tyre pressure gauge only and additional air cannot be added.)

**B13.7.4** To aid engine starting in all kart classes, spark plugs may be removed / replaced and carburettor jets may be adjusted to karts on the dummy grid. (Tools shall be limited to a spark plug spanner and a screwdriver).

**B13.7.5** To aid engine starting, Class 13 karts shall also be permitted to remove the air filter whilst on the grid. (Tools shall be limited to a single screwdriver).

**B13.8** Karts will be formed up in the dummy grid and will be push started when authorized by the Paddock official following the Green Flag being shown.

**B13.9** Each track will establish a 'Failed Start Line'. Any competitor who, having passed that 'Safety Line', receives assistance from anyone other than a signed-on official, may be excluded from the results. If no line is visible on the track, one should be defined by use of an object placed clearly visible at the side of the track. This item should be explained during the drivers briefing.

**B13.10** Drivers will be under Starter's orders from the moment that the Green flag is displayed.

**B13.11** Starts for races shall be:

Non-gearbox karts – A rolling start or a standing start if permitted by the track licence.

**B13.12** In the case of a rolling start, on display of the Green flag, karts will proceed round the course in grid formation at a steady pace to await the starting signal. The karts may be preceded by an official Pace vehicle which will control their speed. If there is no pace vehicle the driver in No. 1 position shall control the speed. When the starter is satisfied that the karts are approaching the start line in correct formation, the starting signal will be given by the red lights going out, or by raising the National flag. It is an offence to break formation before the start of the race has been signalled and may result in the offender being moved to the back of the grid or otherwise penalised. Such penalties will not incur points or be recorded

on a competition licence. It is recommended practice that an object be placed clearly visible at the side of the track a distance before the start line. The line that this object represents should be treated in a way that acceleration for a race start before this point is prohibited and may result in a penalty should persistent breaches of this be observed.

**B13.13** The Clerk of the Course (or their designated representative) may decide to stop a race or practice. Should a race be stopped by the display of red flags the following procedures shall apply:

**B13.14**

- If 25% or less of the race distance has been completed by the leader, the race shall be abandoned, or if possible, the race should be re-run in its entirety. Unless re-run the race will be null and void.

If more than 25% but less than 75% has been completed by the leader, the Clerk of the Course shall, at their discretion, decide to:-

1. Abandon the race, in which case the race (result) shall be declared as the order of finishing the race leader on the last full lap completed and before the race was stopped.
2. Consider the race suspended and run it as a two-part race. In this case, the karts will be restarted in a single file, rolling start. The starting order for the second part of the race shall be the order at the last full lap completed, before the race was stopped. 'Drivers one lap down' shall be put in their correct position i.e., behind the drivers on the same lap as the leader. The race distance shall be the number of laps required to make up the full race distance. The finishing order of the second part, shall be the finishing order of the race (drivers' one lap down' in the first part shall be deemed to have finished the race 'one lap down' unless they have unlapped themselves).
3. Re-run the race in its entirety. If the race is to be re-run or completed the following will apply: While the race is stopped, the

whole course shall be considered as Parc Ferme and no work may be carried out to any kart. Mechanics will not be allowed on the circuit until permission is given by the Clerk of the Course and they, or Incident Marshals already on the circuit, shall not approach or touch any kart until permission is given. If/when authorised by the Clerk of the Course spark plugs may be changed and finger adjustments may be made to the carburettor settings. If a kart leaves the circuit during the stoppage, it will not be permitted to rejoin the race. Any kart not racing before the incident, that caused the race to be stopped, shall not rejoin the re-started race. Karts involved in the incident that gave rise to the stoppage or who subsequently stopped racing prior to the displaying of the red flag because of the incident, may only re-join the race if the Clerk of the Course, in consultation with the Chief Scrutineer, is satisfied that a kart is safe to continue without repair, and the Chief Medical Officer is satisfied a competitor is fit to continue racing and they must start at the rear, whether it is run over the full race distance or as a two-part race. Those karts that stopped after the incident that gave rise to the stoppage because they were instructed to do so or because the track was blocked, may join the restarted race in their proper place. Exceptionally, if it is decided to run the race in its entirety but becomes necessary to remove all karts from the circuit, repairs may be made and all karts that came under starter's orders for the original race will be permitted to start the re-run race from the dummy grid in their original positions.

- If 75% or more of the race distance has been completed by the leader, the race will be deemed to have ended. The race results shall be declared as the lap completed by him before the race was stopped.

If the red flag comes out after the leader has passed the chequered flag but other karts, not involved in the incident related

to the red flag are still on the circuit, then the race results shall be declared as the lap completed by him the leader before passing the chequered flag.

Any Kart which is judged, by an official, to have been stationary at the time the red flag is issued will be classified as DNF in the results, even if running on the previous lap.

### **B13.15 Race Finish**

After receiving the end of race signals all karts must proceed directly to the Parc Ferme without stopping, without giving or receiving any object whatsoever and without any assistance (except that of marshals, if necessary). Any classified kart unable to reach the Parc Ferme by its own means will be placed under the control of marshals who will supervise the movement of the kart to the Parc Ferme.

### **B13.17 Parc Ferme**

- Only authorised officials may enter the Parc Ferme. No intervention of any kind is allowed there unless authorised by such officials.
- When the Parc Ferme is in use, Parc Ferme regulations will also apply in the area between the finishing line and the Parc Ferme entrance.
- Only the driver and one helper, who should have the appropriate grid pass available for inspection, are permitted per kart. (Exceptionally for direct-drive karts, additional grid passes may be issued to 'pushers' on request).

### **B14. Penalties**

**B14.1** Any breach of these regulations may result in the application of a penalty.

**B14.2** The penalties shall be as laid down in Appendix A.

### **B15. Protests and Appeals**

**B15.1.1** All disputes, complaints, grievances and protests between drivers and/or team members, or against NatSKA and/or its officials, must be pursued through a Team Leader and that any persons taking direct action to address their grievances will render the driver and/or team liable to penalty.

**B15.1.2** Any protest or appeal shall be lodged with the Secretary of the Meeting in accordance with regulation B15.2, in writing on the appropriate form (Form F10), stating the grounds for the protest or appeal, by the team leader alone, together with the appropriate fee. The fee for a protest or appeal is £150. Protests and appeals will only be accepted from Team Leaders of directly involved parties.

**B15.2.1** Protests relating to a racing incident must be lodged no later than 30 minutes after the end of the heat in which the incident occurred.

**B15.2.2** Protests relating to posted results must be lodged no later than 30 minutes after the posting of said result.

**B15.2.3** Appeals must be lodged within 30 minutes of the result of the protest to which the appeal relates being posted.

**B15.2.4** All timings made by the officials of the meeting shall be deemed accurate and shall be those used.

**B15.3** The parties must have the details of the decision explained to them before any public announcement is made.

### **B16. Additional Notes for Organisers**

**B16.1** The organisers of an event will, if possible, provide a dimensioned drawing of the circuit.

**B16.2.1** The organisers of a race meeting must use the NatSKA scrutineering/signing on sheet. Only the current form number F09 may be used.

**B16.2.2** Team leaders must ensure that everyone, (any adult helpers over 18 years of age and any helpers under 18 years of age) sign the Team Helpers Signing On sheet (Form No. F11). This must be handed in at race control when the team leader signs on. Any late comers will be expected to visit race control to sign on after the form is handed in.

**B16.2.3** Team leaders must ensure that any officials under the age of 18 years sign on the Under 18s signing on form in Race Control and that this is counter-signed by the appropriate adult / parent.

**B16.3** All requests for Motorsport UK permits must be notified to the NatSKA Committee. Dates and venues for all meetings should be sent to the NatSKA Competition Secretary as early as possible so that all members may be given a full calendar of events.

**B16.4** The organisers of an event shall be responsible for competitors signing on sheets, including examining licences. They should also maintain a record of novice drivers.

**B16.5** It is recommended that drip trays shall be used in the paddock to minimise the effect of oil spillage. The pits and paddock shall be left in a clean, neat and tidy state at the end of any NatSKA event.

**B16.7** A disabled driver will be permitted up to three adult assistants on the circuit (provided that the assistants have signed on) to assist with moving the kart to a safe place in the event that the driver fails to finish an event. The assistant must not restart the kart if it should stall or stop in a position that would be the cause of an able bodied driver withdrawing from an event, i.e. if the kart is beached on a kerb or stuck in long grass.

**B16.8** The running in of engines during a race is not permitted.

**B16.9** Organisers should ensure that results are ready for prize giving ten minutes after the 30 minutes allowed for protest, although with the consent of all Team Leaders present at the meeting, this 30 minute protest period may be reduced in order to expedite the prize giving presentation. Should a protest occur then results should be announced, and prizes given for classes that are not under a protest. Protested classes should be announced within ten minutes of the conclusion after protest.

**B16.10** Best efforts should be made by the organisers to:

**B16.10.1** Publish a programme of events 3 days in advance of every race meeting;

**B16.10.2** Include timings through the day within the programme, including but not limited to:

**B16.10.2.1** Which circuit is to be used when the venue has alternative track layouts

**B16.10.2.2** Scrutineers briefing and Scrutineering

**B16.10.2.3** Team Leaders and Drivers briefings

**B16.10.2.4** Practice / Carb Checks & Emergency practice (including a planned number of laps or time length of session)

**B16.10.2.5** Heats (including a planned number of laps or time length of session)

**B16.10.2.6** Position of breaks

**B16.10.2.7** A description of prizes, allocation and awards procedure and participants;

**B16.10.3** Make the information in B16.10.2 available on the website where possible;

**B16.11** Full race results (heats / final results and championship standings) are to be published on the NatSKA website and/or other Internet accessible locations within 14 days of the race meeting.

## **B17. Useful Checks**

**B17.1** It is worthwhile inspecting and lubricating karts before each drive and Team Leaders should actively encourage drivers and team members to do so.

**B17.2** Special attention should be paid to brakes, steering, wheels and bearings, fuel tap (is it turned on), engine mountings, kart number (correct and legible), position of ignition cut-out, throttle return spring, checking fuel pipes for leaks, checking chassis for cracks and breaks, inspecting and lubricating chain and ensuring that the drivers safety clothing conforms to the regulations.

## **B18. Spectators and Dogs**

**B18.1** Spectators must be behind barriers where applicable and under control. Dogs shall at all times be kept on a lead while at the circuit and are not permitted in the dummy grid area. There are circuits which do not allow dogs to be present, if this is the case a notice of this will be made in the Final Instructions or to Team Leaders in advance.

## **B19. Definitions**

**B19.1** A **meeting or event** is defined as being all sessions of practice or racing from

signing on to prize giving which may span more than one day.

**B19.2 A session** is defined as one complete run through of all classes involved in a meeting or event.

**B19.3 A heat** is defined as an individual race, practice, enduro, or final for a class, or group of classes competing together in accordance with regulation D7, within a session.

**B19.4 The Organisers** are defined as any person who has an involvement in the setting up of a meeting and the running of a meeting on behalf of NatSKA.

**B19.5 The Committee** are defined as the committee members and directors of NatSKA.

**B19.6 A Novice Racer** is defined as a driver who is racing off the back of the grid for the class they have just entered.

**B19.7 An Official** is defined as any person who is acting under the role as defined in B5

**B19.8 A race** is defined as any heat which counts towards a placing in the results.

**B19.9 A Team Leader** is defined as the person or persons accredited by the school/college governors or the governing body of the youth group (or their representative) and NatSKA to be responsible for the karting of that group at the time of the meeting.

**B19.10 An adult helper** is defined as any person over the age of 18 who will assist or take part in any activities during the course of the meeting, who is not a signed on driver for that meeting.

**B19.11 Grid positions** are defined as the positions karts will start in for a heat or final and will normally be determined by a random method for the first grid and then in as fair a method as possible thereafter. Single races may be determined by ballot.

**B19.12 Grid** is defined as the number of signed on entries per class. Where the number of entries exceeds the permitted maximum for the circuit and the grid is "split", the entries will be divided into as near as possible equal number for each of their grids. Where there is a "split grid" in operation, the

number of signed on entries in that class will be used for the calculation of DNF and DNS.

**B19.13 Non Starting Kart** is defined as a kart which has failed to pass the official start line as indicated by the starter's signal.

**B19.14 Practice** is defined as any heat which does not count towards any placing in any results.

**B19.14 Goldcard Holders** are defined as trained helpers who have shown their knowledge of safety scrutineering of karts.

**B19.15 Cadet Racer** is defined as a person aged between 8 and 10 who is restricted to driving karts within the cadet class only. A driver may however remain within the Cadet Classes 1 or 4 up to the 13th birthday, provided that once they have competed in another class, they may not return to Classes 1 or 4 (Ref. D4.1.13).

**B19.16 Timed qualifying** is defined as any heat which is used as a pre race event and the results of which may be used to produce the grids or counted towards the overall results.

**B19.17 Minimum weight** is defined as the combined weight of the kart including that of the driver in full normal racewear.

## **B20 Lap Scoring**

**B20.1** Lap scoring should take the form of at least three people independently observing the drivers, this is important should a dispute arise in order that a majority decision may be made.

**B20.2** The practice of one person "calling" the drivers is not encouraged.

**B20.3** If transponders are used then there should be at least one manual lap scorer.

## **B21 Novices**

**B21.1** Where ever possible, the organisers will try to have novices gridded and to do a formation lap at all race meetings.

## **B22 Trophies**

**B22.1** At each event trophies will normally be presented to 1 in 3 places for the number of entrants in each class. A minimum of two entrants are required in a class for a trophy / medal to be awarded.

**B22.2** At each Enduro event a perpetual trophy will be presented to the class winner, and must be returned on request ready for the next presentation.

**B22.3** At each National Sprint Championship a perpetual trophy will be presented to the class winner, and must be returned on request ready for the next presentation. A minimum of two entrants are required in a class for a trophy / medal to be awarded.

### **B23 Dates**

**B23.1** Licence Dates will run from 1<sup>st</sup> September to 31<sup>st</sup> August.

**B23.2** Race Year will run from 1<sup>st</sup> January to 31<sup>st</sup> December.

**B23.3** Regulations Validity will run from 1<sup>st</sup> January to 31<sup>st</sup> December.

**B23.4** Membership date will run from one AGM to the day before the next.

### **B24 Grid Passes**

**B24.1** Authorised helpers must wear a valid Grid Pass to gain access to the Grid and Parc Ferme. Grid Passes shall be prominently worn so that they can easily be seen.

**B24.2** One Grid Pass will be issued free of charge for every kart number registered to a Team in August/September each year and shall be valid until the end of the following July. New race numbers issued by the Numbers Co-ordinator during the course of a season will also be issued free of charge. Replacement Grid Passes will be issued upon application to the Numbers Co-ordinator, at a cost of £5.00. Temporary Grid Passes, valid for one meeting only, will be available from Race Control at a cost of £2.00.

## Part C: Kart Specifications

### C1. Chassis

**C1.1** The chassis in general shall be of safe, sound and adequately strong construction, shall not include any components of a temporary nature, and shall comply with the following requirements:

**C1.1.1 Wheel Base** - Minimum 101cm, maximum 127cm, on both sides.

**C1.1.2 Length** - Maximum overall length of kart 210cm including bodywork.

**C1.1.3 Track** - Minimum of two-thirds of the measurement of the wheelbase. Maximum 140cm measured to the outside of the wheels or tyres which ever is the greater.

**C1.1.4 Height** - Maximum overall height of any part of the Kart from the ground 60cm except for a structure solely designed as a headrest.

**C1.1.4.1 Weight** – Except where D4.15.9 applies, no kart to be more than 100kg without driver. The weight of a kart is the total weight in full race condition. If it is necessary to use ballast in order to achieve a minimum weight, then no more than 25kg may be used. No single piece of ballast may be more than 5kg and must be securely attached by at least two mechanical fixings of at least 8mm diameter. No solid object (excluding jewellery/dog tags) may be carried on the driver's person.

**C1.1.4.2 Kart-to-Driver Weight Ratios** - In all non-Cadet classes, the following kart-to-driver weight ratios will apply:

For classes with an entry age below the year of the 13th birthday, the ratio will be no greater than 2.5:1. (This therefore applies to Classes 5, 7, 10, 11, 12, 13 and 14).

For classes with an entry age of the year of the 13th birthday or above, the ratio will be no greater than 2.6:1. (This therefore applies to Classes 8 and 15).

**C1.1.5 Generally** - No detailed specification as to design is laid down, but whatever the construction it must be judged safe by the Chief Scrutineer. It must perform safely and present no special hazard to its driver or any other competitor.

**C1.1.6 Numbers** - Each chassis will be allocated a national number for each meeting which shall be displayed on number plates, in accordance with regulations C16 and D5

**C1.1.7 Scrutineering Checks** – It is the competitor and Team Leader's responsibility for removing any part or component of a kart at the request of a Scrutineer, this will be returned to the competitor/Team Leader when inspection is completed for them to re-assemble.

**C1.1.8** Use of torsion bars will be permitted in all classes, except in the Cadet Classes 1 and 4 (Ref D4.1.5).

### C2. Wheels and Tyres

**C2.1** The wheels must be equipped with pneumatic tyres with minimum and maximum external diameters of 22.2cm and 44.1cm respectively.

**C2.2** The attachment of the wheels/hubs to the axles must incorporate a safety locking system such as split pins or self-locking nuts.

**C2.3** In the event that a meeting is declared "open" wet or dry tyres may be used. The two shall not be mixed in any combination. (That is tyres must all be of the same type, either all slick or all grooved). In the event that a meeting is declared "wet" only wet tyres (see D2.7 definition of wet tyres) may be used. In the event that a meeting is declared "dry" only dry tyres may be used.

**C2.4** The use of a tyre sniffing device is permitted.

### C3. Bodywork

**C3.1** No form of bodywork may extend behind the rear bumpers. Nothing except a bubble shield, if fitted, may be vertically above any portion of the driver's head, body or limbs. Any form of bodywork must be soundly constructed and designed to provide maximum safety. No bodywork may exceed a height of 50cm.

### C4. Bumpers and Side Pods

**C4.1** The kart must have protection (bumpers) connected to the chassis at the front and rear which shall have a strength



and construction appropriate to their function. They shall be designed to minimise the risk of the front wheels of a kart being able to ride up over the wheels of another kart in the event of a collision. As a maximum they shall not extend beyond the outer rims of the wheels, at any time, and as a minimum they shall extend to the centre line of the tyre, with the wheels in the straight ahead position.

**C4.2** Both front and rear bumpers shall be parallel to the rear axle of the kart.

**C4.3** No part of the kart or driver may protrude beyond the bumpers or chassis members except wheels, tyres, nose cone and side pods. See Appendix P.

**C4.4** The front bumper for karts of all classes shall comprise:

**C4.4.2** a commercial front fairing must:

- comprise on its front face, centrally located, a vertical surface (with a tolerance of  $\pm 5^\circ$  in relation to the theoretical vertical plane) with a minimum height of 50mm and a minimum length of 300mm located immediately above the ground clearance.
- Not be designed to hold back water, gravel or any other substance.
- Have a ground clearance of 25 mm minimum, 60 mm maximum

that is securely attached to a front bumper which comprises a minimum of a single tube, the top of which must be a maximum of 22cm and a minimum of 15cm above the ground, presenting a flat surface a minimum of 30cm wide and linked to the chassis side members and reinforced by either two tubes, which when viewed from the side must be vertical, firmly attached to the chassis. These tubes shall be a minimum of 20cm apart or in the case of front fairings designed to work without vertical tubes a single, central metal or Plastic/Nylon clamp designed to hold the bumper tube in a position so as to lock the commercial front fairing in place. Two commercial metal clips for the fitment of such fairings must be attached to the upper bumper tube and the chassis, used in the way they were designed and cable tied to the chassis.

Any steel tubing used to hold the fairing to the kart must be attached to the chassis frame by 4 points and be independent from the attachment of the pedals.

**C4.5.1** The rear bumper for karts of all classes except those where C4.10 applies shall consist of two horizontal and parallel rails with outer extensions forming a closed loop, to be made from at least 18mm diameter tube of at least 16swg thickness material, with two vertical link tubes not more than 25cm apart. The lower rail shall cover, as a minimum the distance between the outer chassis rails. The upper rail and the uppermost extension element must be between 16cms and 30cms above the ground in dry configuration and be made of tube of at least 18mm diameter with a wall thickness of at least 16swg. No corner of the bumper, when viewed from behind, shall have an external radius of less than 5cm. The lower rail to be up to 13cm above and parallel to the ground in dry configuration. In a side view the bumper must present a vertical flat face to the rear of at least the distance between the outer chassis rails. Rear bumpers that comply with Motorsport UK competitor's regulations 17.8.1-17.8.9 may be used.

**C4.5.2** The overall width of the bumper for karts of all classes must not exceed the width of the rear of the kart at any time, measurement to be taken to the outside of the wheels or tyres, whichever is the greater and must cover at least 50% of the width of each rear tyre.

**C4.6** Further guidance regarding front and rear bumpers is given in appendices L and M.

**C4.7** Side Pods

**C4.7.1** Lateral Bumpers or side pods must be fitted to all classes of kart on both sides and shall comply with the requirements of Appendix P. CIK homologated and crash-tested bodywork must be fitted to all post-2003 homologated chassis. Pre-2003 homologated chassis must be fitted with CIK homologated side pods but may utilise the original side bars and attachment points.

**C4.7.3** Side pods must not extend beyond the plane through the outside of the front and rear tyres with the front tyres in the straight ahead position in dry conditions and shall cover two thirds of each rear tyre at all times. In wet conditions the pods may not be located outside the plane passing through the outer edge of the rear wheels. The bottom face of the side pod shall be a maximum distance as per Appendix P above the ground with the driver in the kart. The surface of the pods must be uniform and smooth. The pod on the engine side may incorporate the possibility of being used as a noise box for the engine intake. Pods may be modified to incorporate provision for an air box, radiator and starter access. No other modifications are permitted. Side pods must be securely fixed to the side pod bars by a minimum of four points each and will incorporate lateral support to the bottom and face nearest the kart unless homologated otherwise. Side pod support bars must be positively attached to the chassis by a minimum of two fixing points each side.

**C4.8** Karts with bodywork shall carry front and rear bumpers, as above, securely attached to the chassis.

**C4.9** All front, rear and lateral bumpers shall be free of grease or oil.

**C4.10** It is acceptable for the new CIK plastic bumper to be used on the relevant approved CIK homologated chassis.

**C4.11** Front (Nassau) Panel must:

**C4.11.1** Not be located above the horizontal plane through the top of the steering wheel.

**C4.11.2** Allow a gap of at least 50mm between it and the steering wheel at all times.

**C4.11.3** Not protrude beyond the front fairing.

**C4.11.4** Have its lower part solidly attached to the chassis frame, and not the front fairing or bumper bars. Should a spacing device be required this should be made from metal.

**C4.11.5** Have its top part solidly attached to the steering column support with one or more independent bars.

## **C5. Steering**

**C5.1** Steering must be controlled by a steering wheel, which must have a circular shape, and be completely closed. The upper part above 2/3 of the circumference of the wheel may be flat. Flexible steering controls by cable or chain are prohibited. All parts of the steering must have a method of attachment offering maximum safety such as split pins, self-locking nuts. A fixture (jubilee clip or locking collar) shall be fitted to the steering column, below the top support; to prevent the steering column becoming detached should the bottom fastening fail.

## **C6. Brakes**

**C6.1** The minimum is efficient braking, foot operated, on both rear wheels for all classes. Brakes must be either drum or disc type. If a hydraulic system is used, the master cylinder must be fitted in a position safe from impact; hydraulic pipes shall be protected against damage. A secondary connection comprising a rod or cable of 1.8mm minimum diameter and fit for purpose of sufficient strength to operate the braking system in the event of failure of the primary connection shall be fitted between the pedal and the operating mechanism of the brake.

**C6.2** Any chassis where the brake disc comes level with or protrudes below the level of the chassis must be fitted with a protection device attached laterally to the chassis parallel to the brake disc. This protection device must protrude below the lowest level of the brake disc at every point.

**C6.3** A Protection device may be made of any materials except metal and carbon fibre.

## **C7. Exhausts**

**C7.1** Silencers are compulsory and must be so designed that exhaust gases are carried away from and to the rear of the driver (except where this is prevented by the engine design in a Box Stock class). No part of the silencer or exhaust pipe shall protrude rearward beyond the chassis or bumpers, or sideways beyond a line drawn between the outer edges of the front and rear tyres. The open end must point sideways and downwards so as not to present a hazard.

The exhaust system must not constitute a hazard to the driver when he or she is in the normal driving position. Maximum sound levels will be 108 dBA with a microphone set at 1.8m +/- 0.1m above the track, or 105 dBA with a microphone set at 3.6m +/- 0.1m above the track. These maximum values include any tolerance permitted. Tests shall be conducted using a microphone suspended over the track above the normal driving line and connected by cable to the sound level meter. The microphone should be positioned above a straight section of track at a point where karts are at maximum power and in a position where the effects of ambient and reflected sound are minimised. The officials of any meeting reserve the right to exclude any kart, which in their view is clearly noisier than the others. (Event organisers are reminded that a noise meter must be in use at all times.)

**C7.1.1** If overhead readings not taken then drive by readings can be used at a maximum of 105db.

**C7.1.2** Drive by readings:

Will consist of sound readings taken with equipment equal to or better than the minimum requirements of the current Motorsport UK British Motorsport Yearbook (Competitors and Officials), from any point on the public side of the track fence with the meter at a height of 1000mm minimum from the ground and 3000mm from the track edge and the background noise to be at least 10db below the measured level.

**C7.1.3** The organisers of a meeting may appoint an official to record sound readings. Any noise readings above the prescribed limits will be reported to the Chief Scrutineer.

**C7.2** In classes 7, 8 and 14 exhaust flex must be wrapped with suitable proprietary webbing designed for the purpose in order to reduce noise.

## C8. Pedals

**C8.1** Whatever the position of the pedals, they must not protrude forward of the chassis including the bumper. The accelerator must be operated by a pedal equipped with a return spring and provision must be made at

the carburettor for the throttle to be fully closed to the stop when the pedal is released, or in the event of a break in the linkage.

## C9. Transmission and Chain Guards

**C9.1** The drive shall always be to the rear wheels. All automatic methods of chain oiling and greasing are forbidden. A chain guard covering the chain, engine sprocket and rear axle sprocket is compulsory. Protection must be provided over the top and both sides of the chain and sprockets and extended to at least the lower plane of the rear axle. It must not be possible for a finger to be inserted into the transmission in the areas covered by the mandatory guard. Access for starters is permitted. Clutches on non-gearbox karts must be covered, metal guards are recommended. Refer to figure C9.

Figure C9

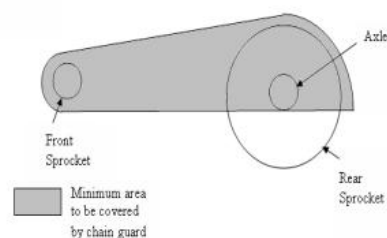

**C9.2** A protection device (as per C6.3) may be used on either side of the sprocket. This must be attached directly to and parallel with the sprocket.

## C10. Flooring

**C10.1** All karts must have flooring made from rigid material that stretches from the seat to the front of the chassis, which must be attached with bolts. There must be no possibility of the drivers' feet coming into contact with the track surface.

## C11. Seating

**C11.1** The seat must provide adequate back and lateral support. The legs of the driver must always be in the front half of the kart.

**C11.2** It is recommended that the seat be made of fire retardant material. It must be rigidly located on the chassis and designed

to securely locate the driver without movement relative to the chassis when cornering or braking.

**C11.3** It is mandatory that all seats comprise metal or nylon reinforcement at all their anchorage points (including seat stays) between the supports and the seat. Reinforcements must have a minimum thickness of 1.5mm and a minimum diameter of 40mm. All seat supports must be securely welded or bolted to the chassis.

### **C12. Self Starting Karts**

**C12.1** In the case of karts capable of self-starting, i.e. by means of an electric starter or recoil pull cord, the following shall apply:

**C12.1.1** the kart must be fitted with a functional on/off switch, capable of being operated by the seated driver with a gloved hand, the on and off positions must be clearly marked; and

**C12.1.2** the driver must be in the driver's seat when the engine is started, with the brake on.

### **C13. Fuel and Oil Containers**

**C13.1** Containers may be of any appropriate material provided they are of leak proof construction and securely mounted. They must not project beyond any of the permanent elements of the chassis at the front or rear.

### **C14. Fuel Pipes and Feeds**

**C14.1** Pipes and feeds must be flexible or have flexible inserts. A positive means of turning off the fuel for gravity feeds shall be easily operable by a gloved hand. Adequate provision must be made to see that any overflow of fuel from vented caps shall not be discharged in a manner that will present a hazard or inconvenience to other drivers. High level or gravity fed fuel tanks are not permitted vertically above any part of the engine and/or exhaust, except where supplied integrally with the engine by the manufacturer. In any case, no part of the tank may be above the top of the seat.

### **C15. Fuel and Oils**

**C15.1** Any unleaded pump fuel as available from any roadside filling station in the UK. No special race fuels or additives other than two stroke oil allowed.

### **C16. Number Plates**

**C16.1** All karts shall be fitted with 4 number plates, which shall be fitted to the front rear and both sides of the kart in clearly visible positions. They must be square in shape and measure 20.5cm. The numbers must be at least 15cm high and each stroke at least 2cm wide. The number plates shall not be made of metal but of a flexible material which is supple enough to be bent through a right angle, and shall have radiused corners. Number plates must be attached securely and must not be deflected by airflow and be clearly legible. The legibility of the numbers shall be subject to the lapscorer's / scrutineer's approval.

**C16.1.2** Where a driver is instructed to renew his/her race numbers on the grounds of illegibility (as requested in the first instance by the Scrutineer) the numbers MUST be changed before the next heat for that kart. Failure to comply with this instruction will result in a penalty for technical non-compliance.

**C16.2** Disabled drivers shall carry an additional rear number plate which shall be orange and carry a black letter "A".

### **C17. Aerofoils**

**C17.1** No form of aerofoil shall be fitted to any kart.

### **C18. Suppression**

**C18.1** The engine must be fitted with a radio interference suppresser.

### **C19. Rear Axle**

**C19.1** Care must be taken to ensure that rear hubs are used in the way for which they were designed, i.e. they must not overhang the end of the axle unless they were designed to do so and are provided with suitable fixing methods.

## **C20. Hand Controls for Disabled Drivers**

**C20.1** Special dispensation can be given to any group who have children with lower limb disabilities requiring hand controlled karts, as approved by Motorsport UK, to use modified proprietary chassis to cater for their needs.

## **C21. Radiator**

**C21.1** All karts requiring cooling radiators must meet the following requirements.

**C21.1.1** The radiator must be fitted to the left hand side of the kart, except in class 15 where it must be fitted as supplied by Rotax,

**C21.1.2** The use of thermal barrier coatings on or in the engine or exhaust system is not allowed.

**C21.1.3** Blanking of the radiator to control engine temperature is free. The use of 'tear off strips' are not permitted. Strong tape may be used providing it is wrapped all the way around the radiator,

**C21.1.4** The use of thermostatic devices is allowed,

**C21.1.5** Minor repairs to the radiator are allowed,

**C21.1.6** All radiators must incorporate a catch tank for the overflow of coolant from the radiator,

**C21.1.7** The radiator cap must have a fixing to prevent it from unscrewing and or falling off, where possible,

**C21.1.8** The use of quick-release hose breaks are allowed,

**C21.1.9** All the hoses must be of a material designed to withstand suitable heat and pressure, and must be secured by clips of a suitable strength to withstand their operating conditions,

**C21.1.10** It is recommended that the hose pipes are securely fastened down in at least two points to prevent contact with the exhaust, axle, brakes or other damaging components,

**C21.1.11** It must be noted that in the case of class 15 the specified regulations laid out by Rotax concerning the radiator must also be adhered to.

## **C22 Transponders**

**C22.1** Transponders must be fitted to the rear of the seat at a height of 250mm ± 50mm

**C22.2** Transponders must be securely fitted with the holed tab uppermost. The fixings may be via a specifically made holder, or by use of at least two cable ties of which at least one must ensure the transponder cannot slip out of it holding by passing through the holed tab.

**C22.3** The driver is held responsible for any loss or damage to the transponder and replacement costs will have to be paid for by that driver.

**C22.4** It is the responsibility of the driver to ensure that all hired transponders are returned to the designated area at the end of each race day.

**C22.5** It is the responsibility of the Competitor who provides their own transponder to make sure the transponder is working correctly and the battery is charged.

**C22.6** If a transponder is taken off the circuit, it is the responsibility of the driver's Team Leader to return it, at the Team's cost, in accordance with the instructions of the Competition Secretary.

## **Part D: Kart Class Rules and Engine Specification**

### **D1. Generally**

**D1.1** All engines and transmissions must comply with these regulations. All modifications not detailed herein must be cleared in the first instance with the Technical Director who must apply to the National Committee for clarification.

**D1.3** If any member is in doubt regarding the regulations clarification should be sought from the committee.

**D1.4** NatSKA reserves the right to add new classes or to delete or alter existing classes, as listed in regulation D4, at an AGM. Any changes made to classes of racing at an AGM will become operative 30 days after the AGM.

**D1.5** Deleted

### **D2. Definitions**

**D2.2 Engine** – to include crankcase, crankshaft and con rod, cylinder, barrel, camshaft (if required by engine type), and head from the same model engine and to be of the original engine manufacturer's specification or pattern to the same specification. After-market ready tuned parts are not allowed. In the case of a gearbox engine being converted to direct drive it is permitted to use two crankshaft halves of the same hand to assist sprocket retention. All engines in all classes must carry an identification number or letter(s), either manufacturer or user applied, in order to match engines to scrutineering sheets, Compliance with this requirement does not affect an engines "box stock" status.

**D2.4 Box Stock** – as supplied by the manufacturer in its original form, with no modification either by the removal or addition or substitution of any material or part that forms the original power unit

### **D2.6 Kart chassis**

**D2.6.1 School built chassis** – a chassis will be considered to be school built if all the chassis members are bent or formed in any school workshop, or the place where the youth group normally meets. Welding or

brazing of the chassis may be carried out elsewhere. The chassis must conform to the NatSKA Kart Specifications for the classes in which it will be entered.

**D2.6.2 Commercial chassis** – any commercially available chassis may be used provided that it conforms to the NatSKA Kart Specifications for the classes in which it will be entered and Regulation D4 allows their use.

**D2.7 Wet tyres** – to qualify as a wet tyre, tyres must be moulded in such a way as to ensure that grooves are created to leave a minimum of 60% and a maximum of 85% of the total surface area as a raised tread pattern. The grooves to have a minimum depth of 2mm at the start of a heat. Hand cutting of all tyres is prohibited.

### **D3. Tuning Modifications in all Classes Except 5, 10, 11, 12 and 14**

**D3.1** Maximum bore size must not exceed the limits set in each class specification.

**D3.2** Over sized barrels may be re-lined to original manufacturer's specification with the same material.

**D3.3** The onus of proof of eligibility of any engine, in any class, is upon the team leader responsible for the entry at the time of the event.

**D3.4** No modification to stroke is permitted.

**D3.5** No modification to the con-rod, as supplied by a commercial manufacturer, is permitted.

**D3.6** No modification to the number of transfer passages or number of inlet ports into the cylinder wall is permitted.

**D3.7** No modification to the number of exhaust ports and passages is permitted.

**D3.8** No externally programmable ignition systems are permitted.

### **D4. Kart Classes**

#### **D4.1 Class 1 – 2 Stroke Cadet Class.**

**D4.1.1** Chassis - This must be any current or previous Motorsport UK homologated Cadet Chassis. This chassis must remain as it was when homologated. The only additions

permitted along with modifications solely concerned with their fitment are; Seats, Nassau Panels, Front Fairing and Ballast, or for repair purposes. Suitable brackets for repairing the engine may be made, but alteration to the core underlying structure of the chassis is prohibited. Chassis dimensions are such that the overall length is a maximum of 170cm, the wheelbase is 90cm  $\pm$  0.5cm, the track as a minimum is 2/3 the wheelbase and as a maximum is 120cm. The chassis must be constructed of 28mm or imperial equivalent tubing. This regulation overrides the requirements of C1.1.1, C1.1.2 and C1.1.3

**D4.1.2 Materials** - The following are specifically prohibited. Parts made from Kevlar, Carbon Fibre (Except Seats), Magnesium and Titanium.

**D4.1.3 Front fairing** - This must comply with C4.4.2 except that its surface face must be a minimum of 250mm by 70mm. There is no mandatory requirement for bodywork fitted to pre-2011 homologated cadet chassis to be CIK crash-tested and homologated. However, CIK Crash-tested and homologated 'Mini Kart' bodywork is mandatory for current homologation Cadet chassis from 1<sup>st</sup> January 2012.

**D4.1.4 Rear bumper** - as per C4.5. A CIK Crash-tested and homologated rear protection system may not be used in lieu of a rear bumper on pre-2011 Cadet chassis.

**D4.1.5 Torsion Bar** - If the chassis is homologated with a torsion bar, this must be fixed and locked in place at all times.

**D4.1.6 Transmission** - must be direct drive and comply with C9

**D4.1.7 Axle** - A solid, or hollow magnetic steel axle of 25mm diameter and minimum 4.5mm wall thickness. Split quick release bearing mountings are not permitted. Must be fitted with circlips on the ends of the axle.

**D4.1.8 Sprockets** - Rear sprocket of 219 pitch, size is free.

**D4.1.9 Tyres** - In dry configuration - "Dunlop SL3 Motorsport UK" front 10x3.6x5, rear 11x5.0x5, in wet configuration - "Dunlop KT3" front 10x3.6x5, rear 11x4.5x5. This

regulation overrides C2.1. Competitors will be restricted to the use of one set of Dry Tyres per race meeting, (except at the National Sprint Championship meeting where tyres may be changed at the end of Friday practice. Competitors will be restricted to the use of one set of Dry Tyres to cover the two days of National Sprint racing). Tyres will be stamped/marked during scrutineering. Tyres sustaining damage during the meeting which renders them unusable may only be replaced at the discretion of the Chief Scrutineer. In such circumstances, it is the responsibility of the driver to ensure that the damaged tyre is inspected by the Chief Scrutineer before the kart exits the circuit/parc ferme.

**D4.1.10 Engines** –

May be any two stroke engine previously or currently specified in a Motorsport UK Kart Yearbook ("Gold Book") for use in Cadet Classes. The engine and ALL ancillaries must comply with the engine section of the relevant Gold Book Cadet Class regulations with the exception that engines do not require to be sealed.

**D4.1.10.1 Class 10 engine** must comply with regulations D4.10.1, 2, 3, 4, 5, 7, 8, 9, 10, 13

**D4.1.11 Weight** - The minimum weight will be 103kg.

**D4.1.13 Ages** - Drivers must be aged between 8 and 13. Once a driver has reached their 10<sup>th</sup> birthday they may transfer to other classes, but once transferred may not return to this class.

#### **D4.4 Class 4 – 4 Stroke Cadet Class.**

**D4.4.1 Chassis** - This must be any current or previous Motorsport UK homologated Cadet Chassis. This chassis must remain as it was when homologated. The only additions permitted along with modifications solely concerned with their fitment are; Seats, Nassau Panels, Front Fairing and Ballast, or for repair purposes. Suitable brackets for repairing the engine may be made, but alteration to the core underlying structure of the chassis is prohibited. Chassis dimensions are such that the overall length is a maximum of 170cm, the wheelbase is

90cm ± 0.5cm, the track as a minimum is 2/3 the wheelbase and as a maximum is 120cm. The chassis must be constructed of 28mm or imperial equivalent tubing. This regulation overrides the requirements of C1.1.1, C1.1.2 and C1.1.3

**D4.4.2** Materials - The following are specifically prohibited. Parts made from Kevlar, Carbon Fibre (Except Seats), Magnesium and Titanium.

**D4.4.3** Front fairing - This must comply with C4.4.2 except that its surface face must be a minimum of 250mm by 70mm. There is no mandatory requirement for bodywork fitted to pre-2011 homologated cadet chassis to be CIK crash-tested and homologated. However, CIK Crash-tested and homologated 'Mini Kart' bodywork is mandatory for current homologation Cadet chassis from 1<sup>st</sup> January 2012.

**D4.4.4** Rear bumper - as per C4.5. A CIK Crash-tested and homologated rear protection system may not be used in lieu of a rear bumper on pre-2011 Cadet chassis.

**D4.4.5** Torsion Bar - If the chassis is homologated with a torsion bar, this must be fixed and locked in place at all times.

**D4.4.6** Transmission - must be direct drive and comply with C9

**D4.4.7** Axle - A solid, or hollow magnetic steel axle of 25mm diameter and minimum 4.5mm wall thickness. Split quick release bearing mountings are not permitted. Must be fitted with circlips on the ends of the axle.

**D4.4.8** Sprockets - Rear sprocket of 219 pitch, size is free.

**D4.4.9** Tyres - In dry configuration - "Dunlop SL3 Motorsport UK" front 10x3.6x5, rear 11x5.0x5, in wet configuration - "Dunlop KT3" front 10x3.6x5, rear 11x4.5x5. This regulation overrides C2.1. Competitors will be restricted to the use of one set of Dry Tyres per race meeting, (except at the National Sprint Championship meeting where tyres may be changed at the end of Friday practice. Competitors will be restricted to the use of one set of Dry Tyres to cover the two days of National Sprint racing). Tyres will be stamped/marked during scrutineering.

Tyres sustaining damage during the meeting which renders them unusable may only be replaced at the discretion of the Chief Scrutineer. In such circumstances, it is the responsibility of the driver to ensure that the damaged tyre is inspected by the Chief Scrutineer before the kart exits the circuit/parc ferme.

**D4.4.10** Engines –

May be any four stroke engine previously or currently specified in a Motorsport UK Kart Yearbook ("Gold Book") for use in Cadet Classes. The engine and ALL ancillaries must comply with the engine section of the relevant Gold Book Cadet Class regulations with the exception of regulations D4.4.10.1 and D4.4.10.2; or NatSKA Class 11 compliant engine (D4.4.10.3)

**D4.4.10.1** Exhaust – The exhaust fitted to the Honda GX-160 engine should meet the requirements of Section 4 of NatSKA Appendix J (ie either use a standard exhaust or one modified and sealed by an agent.

**D4.4.10.2** Sealing – Engines do not require to be sealed.

**D4.4.10.3** Class 11 engine must comply with regulation D4.11.2 (NatSKA specification engine)

**D4.4.11** Weight - The minimum weight will be 103kg.

**D4.4.13** Ages - Drivers must be aged between 8 and 13. Once a driver has reached their 10<sup>th</sup> birthday they may transfer to other classes, but once transferred may not return to this class.

## **D4.5 Class 5: 80cc Box Stock**

**D4.5.1** Engine – "Box Stock" Comer S80 series production engine to current manufacturer's specification or "Box Stock" Comer K80 series production engine to current manufacturer's specification.

**D4.5.2** No material may be either added to or removed from the supplied power unit.

**D4.5.3** The standard exhaust muffler box to be retained on Comer S80 or K80 engines.

**D4.5.4** The standard Tillotson HL166B or HL166C carburetors, without power-valve,



must be used on the Comer S80 or K80 engines.

**D4.5.5** The centrifugal clutch may be replaced with a manufacturer's alternative or converted to a direct drive sprocket.

**D4.5.6** The pull start mechanism may be removed.

**D4.5.7** Decarbonising may only be undertaken using solvents.

**D4.5.8** Any evidence of the use of abrasive materials/tools will be considered as tuning.

**D4.5.9** The standard spark plug or equivalent must be used.

**D4.5.10** Essential repairs which do not contravene the spirit of 'box stock' engines may be considered acceptable by the Chief Scrutineer or Technical Director. Team leaders are reminded of the provisions of regulation D3.3 and should check before racing that such repairs are acceptable.

**D4.5.11** School built or commercial chassis' may be used.

**D4.5.12** Rear wheel braking only.

**D4.5.13** It is permitted to add a washer or other proprietary item to the high and low jet for the sole purpose of adjusting the carburettor mixture. No other modifications to the carburettor are permitted.

**D4.5.14** The minimum age for this class is 10.

#### **D4.7 Class 7: 100cc Piston Ported**

**D4.7.1** Engine: TKM BT82 with all ancillary components including carburettor, air intake tract, piston and ring(s) (including head volume and squish), ignition system (including spark plug and timing), optional clutch (if fitted), and entire exhaust system including manifold to be compliant with The Junior TKM 2 Stroke section of the current Formula TKM regulations and technical guide (where relevant to the junior engine) as long as not overridden by further regulations in Section D4.7. It is allowed to use clutch components which are not stamped "TKM"

**D4.7.2** Tuning restrictions as in D3.2, 3.3, 3.4, 3.5, 3.6, 3.7 and 3.8.

**D4.7.3** School built or commercial chassis' may be used.

**D4.7.4** Rear wheel braking only.

**D4.7.5** Bumpers must conform to NatSKA specifications defined in regulation C4.

**D4.7.6** Only tyres for use in Motorsport UK Junior Formula TKM classes may be used, i.e. Maxxis Formula TKM tyres, and Maxxis Sport Tyres. This will apply to slicks only. Wet tyres may be the new or old type Formula TKM tyres. Competitors will be restricted to the use of one set of Dry Tyres per race meeting, (except at the National Sprint Championship meeting where tyres may be changed at the end of Friday practice). Tyres will be stamped/marked or bar code read at the end of practice. Tyres sustaining damage during the meeting which renders them unusable may only be replaced at the discretion of the Chief Scrutineer. In such circumstances, it is the responsibility of the driver to ensure that the damaged tyre is inspected by the Chief Scrutineer before the kart exits the circuit/parc ferme.

**D4.7.7** All engines must use a single TKM manufactured aluminium carburettor restrictor plate. This is a flat metal plate with a minimum thickness of 3mm and a central parallel round bore with a maximum diameter as in the table below through which all the mixture feeding the engine must pass. This part must not be modified or polished in any way and must be made and supplied by Tal-Ko. It must display the genuine TKM logo. No blenders are permitted under any circumstances. The table below shows the maximum diameter of the central bore allowable for a kart using the appropriate weight restrictions and colour flashing. All karts must show the appropriate colour flashing in the top left corner of the front number plate. The kart weight and combined driver/kart weight must comply with the restrictor chosen in the table below.

Restrictor	Weight		Flashing
	Max Kart	Min. Kart/ Driver	
19.5mm	<b>86kg</b>	<b>123kg</b>	<b>Black</b>
20.5mm	<b>86kg</b>	<b>128kg</b>	<b>Gold</b>
22.0mm	<b>86kg</b>	<b>135kg</b>	<b>Blue</b>
24.0mm	<b>83kg</b>	<b>142kg</b>	<b>Purple</b>
No Restrictor	<b>81kg</b>	<b>148kg</b>	<b>White</b>

**D4.7.8** All karts shall be fitted with commercial side pods.

**D4.7.9** All exhausts shall be stamped with the genuine TKM logo and be fitted with auxiliary can mufflers with outlet holes pointing downwards towards the track surface. The use of the new 2007 Tal-Ko homologated exhaust is optional. Only a TAG TKM engine may be equipped with the larger TAG exhaust and manifold.

**D4.7.10** A current or previously approved TKM air box must be used, as per the Formula TKM regulations.

**D4.7.11** Drivers must have passed their 12th birthday and have applied for and received a High Power Racing Licence and Signature record card.

**D4.7.12** Additional trophies will be awarded within Class 7 for competitors making a minimum combined kart and driver weight of 158kg; to be referred to as the '**TKM 158 Class**'. Lead may not be added to make the weight. The TKM 158 Class will operate as follows:

- (i) Drivers entering the TKM 158 Class will declare themselves as eligible on their race entry form.
- (ii) The combined kart and driver weight will be recorded by the Chief Scrutineer before racing commences, and after each heat. Competitors failing to make the minimum 158kg weight will cease to be eligible for the TKM 158 Class trophies.
- (iii) TKM 158 trophies will be awarded to 1 in 3 places for the number of entrants, as per B22.1.

(iv) Competitors entered for the TKM 158 Class will also be eligible for the main Class 7 trophies.

#### **D4.8 Class 8: 100cc Rotary/Reed/ Piston Ported**

**D4.8.1** Engine: Any 2 stroke engine with a nominal capacity of 100cc, to a maximum capacity of 106cc.

**D4.8.2** Tuning restrictions as In D3.1, 3.2, 3.3, 3.4, 3.5, 3.6, 3.7 and 3.8.

**D4.8.3** Drivers must have passed their 14th birthday and have applied for and received a High Power Racing Licence.

**D4.8.4** Bumpers must conform to NatSKA specifications defined in regulation C4.

**D4.8.5** Rear wheel braking only.

**D4.8.6:** Carburettor – Any standard butterfly type with centre axle. No modifications other than as specified in D4.8.13 are allowed.

**D4.8.7** All engines must use a single, TKM manufactured, purple anodised, aluminium carburettor restrictor plate. This is a flat metal plate with a minimum thickness of 3mm and a central, parallel and round bore of 24mm maximum diameter through which all the mixture feeding the engine must pass. This part must not be modified or polished in any way other than to drill a single hole for the pulse tube connection to the carburettor. The restrictor must be made and supplied by Tal-Ko. It must display the genuine TKM logo. The original anodised finish of the restrictor must be intact. No blenders are permitted under any circumstances.

**D4.8.9** All karts shall be fitted with commercial side pods.

**D4.8.10** All exhausts shall be fitted with auxiliary can mufflers with outlet holes pointing downwards towards the track surface.

**D4.8.11** All karts to be fitted with an effective CIK approved air box for a 100cc kart.

**D4.8.12** School built or commercial chassis' may be used.

**D4.8.13** It is permitted to

1. add a washer or other proprietary item to the high and low jet for the sole

purpose of adjusting the carburettor mixture and

2. make a small modification to the throttle butterfly for the specific purpose of allowing fuel mixture to provide continued engine lubrication whilst in the closed throttle position.

**D4.8.14** Weight – The minimum weight for kart and driver, as measured immediately on return to parc ferme, shall be 152kg.

**D4.10 Class** Motorsport UK regulated Comer Cadet

**D4.10.1** Engine – Previously Motorsport UK regulated Comer Cadet engine including ancillary specification with the exception that engines do not need to be sealed.

**D4.10.5** The centrifugal clutch may be replaced with a Comer S80/K80 series clutch or converted to a direct drive sprocket.

**D4.10.6** The pull start mechanism may be removed.

**D4.10.7** Decarbonising may only be undertaken using solvents.

**D4.10.8** Any evidence of the use of abrasive materials/tools will be considered as tuning.

**D4.10.9** The standard spark plug or equivalent must be used.

**D4.10.10** Essential repairs which do not contravene the spirit of 'box stock' engines may be considered acceptable by the Chief Scrutineer or Technical Director. Team leaders are reminded of the provisions of regulation D3.3 and should check before racing that such repairs are acceptable.

**D4.10.11** School built or commercial chassis' may be used.

**D4.10.12** Rear wheel braking only.

**D4.10.13** It is permitted to add a washer or other proprietary item to the high and low jet for the sole purpose of adjusting the carburettor mixture. No other modifications to the carburettor are permitted.

**D4.10.14** The minimum age for this class is 10.

**D4.10.15** Spark plug for Comer W60 engine to be Bosch W08AS, W2AS or of an

equivalent type (including Iridium alloy electrodes).

**D4.10.16** Thread recovery systems are allowed on all threads, including the spark plug thread, in the case of which the method used must not decrease the volume of the combustion chamber,

**D4.10.17** Gasket manufacture free. Dimensions to match original Comer parts.

**D4.11 Class 11: 4 Stroke Box Stock Direct Drive Junior**

**D4.11.1** Engine – Honda GX160 Series to comply with regulation D4.11.2 or D4.11.3.

**D4.11.2** Engine to meet specifications as defined in Appendix J (known as the NatSKA specification engine). Essential repairs which do not contravene the spirit of 'box stock' engines may be considered acceptable by the Chief Scrutineer or Technical Director. Team leaders are reminded of the provisions of regulation D3.3 and should check before racing that such repairs are acceptable. A broken baffle section may be removed from an exhaust only if done so by a Motorsport UK / ABKC approved agent and resealed by them after the work is completed.

**D4.11.3** Engine to meet specification as set out both in the current Motorsport UK Kart Race Yearbook and associated GX160 Technical Regulations (known as the Motorsport UK specification engine).

**D4.11.4** School built or commercial chassis' may be used.

**D4.11.5** Rear wheel braking only.

**D4.11.6** Bumpers must conform to NatSKA specifications defined in regulation C4.

**D4.11.7** Bolts shown in Appendix Q must be drilled across their flats with a 2mm diameter hole to enable scrutineers to apply lock wire seals if required. In the event that the scrutineers require that an engine be sealed then all karts in class eleven competing at that meeting shall have their engines sealed.

**D4.11.8** Drivers must have held a full NatSKA Racing Licence for less than 24 months to compete in Class 11. A driver who has finished in the top 40% (rounded up) in

the National Championships must move to Class 12 at the beginning of the new season. Once the driver has held a full NatSKA Racing Licence for 12 months the driver may move up to Class 12, but is obliged to do so on subsequently achieving 3 top three race meeting results. Once the move is made, the driver cannot return to Class 11. After holding a full racing licence for 24 months, the driver will be ineligible for Class 11. For drivers entering Class 11 after transfer from Class 1 or 4 with a full race licence, all the above dates start from the date of transfer.

**D4.11.9** It is permitted to allow the use of a centrally mounted fuel tank. If this is used then a cover plate must be placed over the front and top of the engine. This cover plate must be made from suitable material fit for purpose. It may be necessary to add a pulsed fuel pump which will be vacuum fed from either the governor rod hole or one drilled in the inlet manifold, tapped to accept a vacuum fitting. All fuel pipes must take a direct route to the carburettor and be safely secured to upper side of any chassis parts. The addition of one in-line fuel filter is acceptable. A single pipe may be used to create a return feed to fuel tank.

**D4.11.10** The minimum age for this class is 10.

**D4.11.11** The minimum combined kart and driver must be a minimum of 103kg at all times. The minimum driver weight is 27kg, with only the mandatory items of personal protective equipment as per B11.1.1, B11.1.4, B11.2 and B11.4 to be included when weighing the driver.

#### **D4.12 Class 12: 4 Stroke Box Stock Direct Drive Senior**

**D4.12.1** Engine – Honda GX160 Series to comply with either D4.11.2 or D4.11.3.

**D4.12.2** Drivers must have held a full NatSKA Racing Licence for a minimum of 12 months.

**D4.12.3** Class 11 shall not be run with Class 12 except where specifically allowed by the Supplementary Regulations (as in the event of the National Enduro).

**D4.12.4** It is permitted to allow the use of a centrally mounted fuel tank. If this is used then a cover plate must be placed over the front and top of the engine. This cover plate must be made from suitable material fit for purpose. It may be necessary to add a pulsed fuel pump which will be vacuum fed from either the governor rod hole or one drilled in the inlet manifold, tapped to accept a vacuum fitting. All fuel pipes must take a direct route to the carburettor and be safely secured to upper side of any chassis parts. The addition of one in-line fuel filter is acceptable. A single pipe may be used to create a return feed to fuel tank. 10.

**D4.12.5** The minimum combined kart and driver must be a minimum of 103kg at all times. The minimum driver weight is 27kg, with only the mandatory items of personal protective equipment as per B11.1.1, B11.1.4, B11.2 and B11.4 to be included when weighing the driver.

#### **D4.13 Class 13: High Power 4 Stroke**

**D4.13.1** Engine to be a NatSKA approved engine as specified in Appendix S. Engine and all ancillaries to comply with Appendix S.

**D4.13.2** Drivers must have passed their 12<sup>th</sup> birthday and have applied for and received a High Power Racing Licence.

**D4.13.3** School built or commercially built chassis may be used.

**D4.13.4** Rear wheel braking only.

**D4.13.5** Bumper must conform to the current NatSKA regulations as set out in regulation C4.

**D4.13.6** Tyre types are not restricted other than by regulations controlling safety.

**D4.13.7** Number plates shall be black with white numbers.

**D4.13.8** The restrictions in section D3 are overridden by those in Appendix S

#### **D4.14 Class 14: 85cc Box Stock or Restricted TKM BT82**

**D4.14.1** Engine – “Box Stock” Raket 85 series production engine to current NatSKA fiche.

**D4.14.2** In the case of the Raket engine no material may be either added to or removed from the supplied power unit.

**D4.14.3** The standard exhaust as supplied by the manufacturer to be used on the Raket 85 engine. Lugs may be welded or brazed onto the exhaust silencer to enable longer retainer springs to be fitted.

**D4.14.4** The standard Tillotson HS175 type carburettor as supplied with the engine by the manufacturer must be used on the Raket 85 engine. Addition of the Tillotson HS205 carburettor into the rule book, as stated in the approved NatSKA fiche, which was approved by the Chairman / Technical Director, date of publication 10<sup>th</sup> June 2008.

**D4.14.5** Decarbonising may only be undertaken using solvents.

**D4.14.6** Any evidence of the use of abrasive materials/tools will be considered as tuning.

**D4.14.7** The standard spark plug or equivalent must be used.

**D4.14.8** Essential repairs which do not contravene the spirit of 'box stock' engines may be considered acceptable by the Chief Scrutineer or Technical Director. Team leaders are reminded of the provisions of regulation D3.3 and should check before racing that such repairs are acceptable.

**D4.1 4.9** School built or commercial chassis' may be used.

**D4.14.10** Rear wheel braking only.

**D4.14.11** All karts shall be fitted with a CIK approved air box for a 100cc kart.

**D4.14.12** The minimum age for this class is the year of the 11th birthday.

**D4.14.13** The combined driver / kart weight at the race end shall be a minimum of 123Kg

**D4.14a** As an alternative engine, the TKM BT82 with all ancillary components (including carburettor, air intake tract, piston and ring(s) (including head volume and squish), ignition system (including spark plug and timing), optional clutch (if fitted), and entire exhaust system including manifold) compliant with The Junior TKM 2 Stroke section of the current Formula TKM regulations and technical guide but with the addition of a

NatSKA / Talko specified Class 14 restriction is allowed. All non-engine class requirements are as above in the class regulations. Trophies to be awarded as distinct classes for each engine type and will be referred to as Class 14 Raket and Class 14 TKM respectively. It is allowed to use clutch components which are not stamped "TKM"

**D4.14b** All restricted TKM BT82 engines must use a single TKM manufactured silver aluminium carburettor restrictor plate. This is a flat metal plate with a minimum thickness of 3mm and a central parallel round bored with a maximum diameter of 19mm through which all the mixture feeding into the engine must pass. This part must not be modified in any way and must be made and supplied by Tal-Ko. It must display the genuine TKM logo.

All restricted TKM BT82 engines must also use an exhaust restrictor with a round bore with a maximum diameter of 16.5mm +/- 0.03mm. This part must not be modified in any way and must be made and supplied by Tal-Ko.

**D4.14.15** Only tyres for use in Motorsport UK Junior Formula TKM classes may be used, ie Maxxis Formula TKM tyres, and Maxxis Sport Tyres. This will apply to slicks only. Wet tyres may be the new or old type Formula TKM tyres. Competitors will be restricted to the use of one set of Dry Tyres per race meeting, (except at the National Sprint Championship meeting where tyres may be changed at the end of Friday practice). Tyres will be stamped/marked or bar code read at the end of practice. Tyres sustaining damage during the meeting which renders them unusable may only be replaced at the discretion of the Chief Scrutineer. In such circumstances, it is the responsibility of the driver to ensure that the damaged tyre is inspected by the Chief Scrutineer before the kart exits the circuit/parc ferme.

#### **D4.15 Class 15: Rotax Max.**

**D4.15.1** Engine – Rotax FR125 Junior Max and Rotax FR125 Max. Engines to be box stock and adhere to the current Motorsport

UK Rotax FR125 Max Engine and ancillaries fiche and regulations except where overridden below or in Appendix R.

**D4.15.2** The Rotax FR125 Max must be restricted by disabling the exhaust power valve, which must be fixed in the closed position by means of an approved locking kit, supplied by NatSKA. The FR125 Senior Max EVO Electronic / Pneumatic exhaust valve is not permitted.

**D4.15.4.1** Competitors will be restricted to the use of one set of Dry Tyres per race meeting, (except at the National Sprint Championship meeting where tyres may be changed at the end of Friday practice). Tyres will be stamped/marked during scrutineering. Tyres sustaining damage during the meeting which renders them unusable may only be replaced at the discretion of the Chief Scrutineer. In such circumstances, it is the responsibility of the driver to ensure that the damaged tyre is inspected by the Chief Scrutineer before the kart exits the circuit/parc ferme.

**D4.15.4.2** Dry tyres must be those used currently or previously in Rotax Junior Classes in the former Motor Sports Association (MSA) or current Motorsport UK Gold Book. Vega SL8 (marked JAG), Mojo D1 (marked CIK F-O or CIK F-Option), all with yellow bar code, Mojo D2 9 (marked CIK F-Option) with bar code and Maxxis Sport with bar code.

Wet tyres to be any tyre for use in Rotax Junior Classes in the former Motor Sports Association (MSA) or current Motorsport UK Gold Book.

**D4.15.5** Bumpers must conform to NatSKA specifications as defined in Regulation C4.

**D4.15.6** Commercial chassis' must be used and conform to Motorsport UK direct drive regulations.

**D4.15.7** Drivers must have passed their 13th birthday and have applied for and received a High Power Racing Licence.

**D4.15.9** The minimum combined weight of kart and driver will be 148kgs at all times. The maximum kart weight without driver is

108kgs. These weights will be measured on returning to parc ferme after any heat.

**D4.15.14** Additional trophies will be awarded within Class 15 for competitors making a minimum combined kart and driver weight of 162kg; to be referred to as the '**Rotax 162 Class**'. Lead may not be added to make the weight. The Rotax 162 Class will operate as follows:

- (i) Drivers entering the Rotax 162 Class will declare themselves as eligible on their race entry form.
- (ii) The combined kart and driver weight will be recorded by the Chief Scrutineer before racing commences, and after each heat. Competitors failing to make the minimum 162kg weight will cease to be eligible for the Rotax 162 Class trophies.
- (iii) Rotax 162 trophies will be awarded to 1 in 3 places for the number of entrants, as per B22.1.
- (iv) Competitors entered for the Rotax 162 Class will also be eligible for the main Class 15 trophies.

## **D5. Number Plates**

**D5.1** National Sprint titleholders are entitled to use one additional plate bearing the letter S and shall be entitled to use this plate until the next equivalent championship event.

**D5.2** National Enduro titleholders are entitled to use one additional plate bearing the letter E and shall be entitled to use this plate until the next equivalent championship event.

**D5.3** Combined National Sprint and Enduro title holders are entitled to use one additional plate bearing the letters ES and shall be entitled to use this plate until the next equivalent championship event.

**D5.4** All Novice Drivers racing from the back of the grid in a qualified class MUST carry an additional yellow plate bearing the letter N on the rear of their kart during all Sessions. Novices in novice-only practice sessions MAY carry this plate (where the kart is also being used by other drivers racing from the back of the grid) but are not required to do

so. During novice-only practice sessions, racing is not permitted.

**D5.5** There will be a National Numbering System for all karts operating under NatSKA regulations (i.e. at all events requiring Motorsport UK permit granted in the name of NatSKA). It is the team leader's responsibility to apply to the committee for any new kart number to be used by their team. This will then be added to the National Numbering System.

**D5.6** Each class (or pair of classes where classes are combined for event purposes) will have a quota of numbers.

**D5.7** The first 10 numbers in each class will be credited to the top ten places at the National Sprint Championships of the preceding season.

**D5.8** All numbers will be reallocated annually, beginning 1st September each year and shall be valid until 31st August of the following year.

**D6. Numbers and Plate Colours;**

**D6.1 Class 1** - yellow plates - black numbers

**D6.4 Class 4** – yellow plates – red numbers

**D6.5 Class 5** – yellow plates – black numbers

**D6.7 Class 7** - blue plates - white numbers

**D6.8 Class 8** – yellow plates – black numbers

**D6.10 Class 10** - green plates - white numbers

**D6.11 Class 11 NatSKA spec. engine**

red plates - white numbers

**Motorsport UK spec. engine**

Blue plates - white numbers

**D6.12 Class 12 NatSKA spec. engine**

red plates - white numbers

**Motorsport UK spec. engine**

Blue plates - white numbers

**D6.13 Class 13** - black plates - white numbers

**D6.14 Class 14** - yellow plates - red numbers

**D6.15 Class 15** - red plates - white numbers

**D7. Classes which may be combined for event purposes**

**D7.1 Practice Heats**

Classes 1 and 4 cannot be run with any other class.

Classes 10, 11

Classes 5, 10, 11, 12, 14

Classes 7, 8, 13, 15

Novice Practice Heats

Classes 5, 10, 11, 14

**D7.2 Racing Heats**

Classes 5, 10, 11

Classes 5, 14

Classes 7, 8, 13, 15

Classes 12, 14

Classes 12, 10

The above combinations are the recommended groups that may be used to combine grids for any event. The fastest class shall always be placed at the front of the grid. Other combinations may be considered only in exceptional circumstances. For the purposes of the enduro meeting only classes 11 and 12 may be run together.

## Appendix A: Disciplinary Procedures

### Offences

Below are noted specific offences under the NatSKA Regulations, contravention of these regulations or any other regulation not specifically mentioned may result in a penalty being applied. In the event that there is no specific NatSKA regulation, the Motorsport UK British Motor Sports Yearbook (Competitors and Officials) shall apply.

Code	Offence	NatSKA Reg.	Motorsport UK Reg.	Guideline Penalty	Penalty Points
A	A positive result of any test for presence of alcohol or drugs.	B12.1.1	D35.1 H39.1	Disqualification from meeting	6
B	Failure to attend drivers briefing	B10.4	H33.1.3	£10 fine	1
C	Not complying with flag signals before or after the race	B7.2 B7.3	C1.1.6	5 second penalty	1
D	Not complying with flag signals during the race <i>Red/Yellow/Quartered/ Technical</i>	B7.2 B7.3	C1.1.6	10 second penalty 1 lap penalty	2
E	Not complying with flag signals – Black <i>(Ignored more than once)</i>	B7.2 B7.3	C1.1.6	Disqualification from race or Disqualification from meeting	2 or 6
F	Breaking formation before the lights go out	B7.7	U7.8	5 second penalty	1
G	Receiving outside assistance	B13.1.4 B13.9	N/A	Disqualification from race	2
H	Restarting a kart <i>Non onboard starter</i>	B12.16	N/A	Disqualification from race	2
I	Gaining an unfair advantage	B12.6	C2.3.2	5 second penalty 1 lap penalty	1 1
J	Driving in a manner incompatible with general safety.	B12.8	C1.1.9	1 lap penalty Disqualification from race Disqualification from meeting Referred to Stewards	1 3 6 <i>Option of suspension</i>



K	Exceeding Track Limits	B12.6	U12.5.3 U12.5.4	3 <sup>rd</sup> time - 5 second penalty 4 <sup>th</sup> time - 10 second penalty 5 <sup>th</sup> time – disqualification 6 <sup>th</sup> time – Black Flag	1  or 2
L	Scrutineering Non-Compliance	At Chief Scrutineer / Clerk's discretion.		Disqualification from race or Disqualification from meeting	0
M	Abusive language or behaviour, assault or threat of assault within the area under control of NatSKA.	B12.1 B15.1.1	C1.1.9	Disqualification from race. Disqualification from meeting, Referral to the stewards	4  6  Option of suspension
N	Failure to obey the instructions of an official	B12.1	H33.1.3	Disqualification from race Disqualification from meeting	4  6
O	Failure to agree to an eligibility examination	B9.2	U8.1	Disqualification from meeting	6

The Chief Clerk of the Course shall be the first Judicial Body in the case of all the offences noted above. All driving offences need to be included in the final score, otherwise it gives the driver a chance to discard the penalty rendering it irrelevant. (No deterrent value.) Non compliance penalties should remain at the discretion of the Clerk and Chief Scrutineer.

Aggravated and mitigating circumstances may be taken in to account, to alter the severity of any penalty issued.

For the avoidance of doubt, an incident is considered to be aggravated when it is grossly reckless, wilful or premeditated and/or is made more serious by a significant disregard for the safety of others. When 10 second penalty can't be applied then a 5-place penalty will.

NB Motorsport UK stated, with regard to track limits, that the first offence should be allowed without penalty, the second with a warning flag, the third and fourth with a time penalty and the fifth with a race disqualification.

## NatSKA Penalties

One or more of the penalties below may be imposed as appropriate and at the discretion of the Chief Clerk of the Course or the Stewards of the Meeting, and recorded on the NatSKA Driver database. Should a competitor receive twelve penalty points within a period of 12 months, it may at the discretion of the Directors result in the suspension of their licence for up to 3 months or 3 meetings in addition to any other penalty imposed.

Drivers should be aware that serving a suspension will not remove the penalties from the drivers licence database, although on return to racing, all but their six most recent penalty points will be disregarded should further penalty points be accrued. It should be noted however, that drivers amassing twelve penalty points under these arrangements will, at the discretion of the Directors, render themselves liable to further suspension.

Any competitor who receives a suspension or becomes liable to suspension may request a hearing before the Directors of NatSKA to show why his licence should not be suspended or should be suspended for a lesser period. Any such request shall be made in writing and submitted to the Secretary together with a fee of £100, which shall be non-refundable.

Penalty Code	Penalty
1	A reprimand may be imposed by the Clerk of the Course, the stewards of the meeting or Motorsport UK
2	A place penalty of up to five places may be imposed by the Clerk of the Course, the stewards of the meeting or Motorsport UK
3	An exclusion from a heat may be imposed by the Clerk of the Course, the stewards of the meeting or Motorsport UK
4	An exclusion from the meeting may be imposed by the Clerk of the Course, the stewards of the meeting or Motorsport UK

The penalty for failing to attend Drivers' Briefing shall be as noted in Regulation B10.4

For the offences of abusive language or behaviour, assault or the threat thereof (Offence Code O), all penalties imposed by the Chief Clerk of the Course shall be referred to the Stewards of the Meeting who may at their discretion, elect to further increase the penalty on the driver by imposing an immediate sentence of suspension of not more than thirty days. The Stewards may impose a ban for a number of kart meetings rather than days if this is seen to be more appropriate. Alternatively, the Stewards may refer the incident to the Directors for them to consider further penalty.

If the Stewards of the meeting are satisfied that abuse or physical assault or threat thereof is proven then no further appeal against their sentence is permitted. In the event that the stewards find a Novice guilty their licence application will need the additional approval of a NatSKA Director (not from the driver's team).

In the event that a team leader wishes to appeal against a penalty imposed by the Clerk of the Course, said appeal must be made in accordance with Regulation B15. These rules shall apply to the competitor; however, if the offence is committed by a non-driving member of the team then the penalty may be transferred to the driver or the whole team.

Whilst it is at the discretion of the Chief Clerk of the Course as to whether a penalty should be

recorded on the Driver database, this discretion cannot apply to offences relating to;

1. Driving in a manner not compatible with general safety
2. Safety – failure to comply with flags, signals, or instructions
3. General Conduct – Abuse, assault or threats of either.

Any endorsement shall be valid for a period of 12 months from the date of the offence. Endorsements shall be coded as noted above, i.e. a five place penalty for gaining an unfair advantage shall be recorded thus: J2(10/9/13). If a penalty of suspension is imposed the period of the suspension shall be recorded thus: O4(10/9/13)30days.

The Secretary of the Meeting shall pass to the Membership and Licensing Director a list of any penalties and endorsements imposed at any race meeting to ensure the Drivers database is kept up to date.

## Appendix B: Expiry Dates and Fees for NatSKA Licences

Birthday falling on or between	Present School Year	Expires
1 September 2012 to 31 August 2013	Year 3	31 <sup>st</sup> July 2031
1 September 2011 to 31 August 2012	Year 4	31 <sup>st</sup> July 2030
1 September 2010 to 31 August 2011	Year 5	31 <sup>st</sup> July 2029
1 September 2009 to 31 August 2010	Year 6	31 <sup>st</sup> July 2028
1 September 2008 to 31 August 2009	Year 7	31 <sup>st</sup> July 2027
1 September 2007 to 31 August 2008	Year 8	31 <sup>st</sup> July 2026
1 September 2006 to 31 August 2007	Year 9	31 <sup>st</sup> July 2025
1 September 2005 to 31 August 2006	Year 10	31 <sup>st</sup> July 2024
1 September 2004 to 31 August 2005	Year 11	31 <sup>st</sup> July 2023
1 September 2003 to 31 August 2004	Year 12	31 <sup>st</sup> July 2022
1 September 2002 to 31 August 2003	Year 13	31 <sup>st</sup> July 2021

Type	Condition	Current Cost
Novice Licence	Issued prior to first meeting attended	Free
First Full Licence/Upgrade	Expires on the 31 <sup>st</sup> July after 18 <sup>th</sup> birthday	£10.00
Replacement Licence	If lost	£10.00
Replacement Licence	If transferring clubs	Free
Replacement Licence	Updating photo	£5.00
Temporary Licence	Forgotten at race meeting	£5.00

## Appendix C: NatSKA Racing Licence Oral Test

The answers are to be rational and full but may be general descriptions rather than evidence of rote learning.

	Question	Answer
<b>A. Preparation &amp; Safety</b>		
1.	When you arrive at the track, what are the most important things to check on your kart?	<i>Tightness of nuts and bolts, that there is fuel in the tank, that the brakes work properly, the ignition cut out, and the state of the tyres.</i>
2.	How do you check the state of the tyres?	<i>By looking at the tyres for splits and accident damage. Check inflation by using a pressure gauge.</i>
3.	How do you check to see if the brakes are working properly?	<i>Press the brake pedal fully and try to pull/push the kart.</i>
4.	How do you check the ignition cut-out?	<i>By trying to start the engine with the plug out (resting on the engine head), and looking for a spark between the plug and the engine head with the ignition switch in both ON and OFF positions. There should be no spark when the switch is OFF.</i>
<b>B. Clothing</b>		
1.	What is the minimum clothing requirement for karting?	<i>A driving suit that meets CIK/FMK or Motorsport UK standards.</i>
2.	What is the minimum footwear requirement?	<i>Footwear giving protection to the ankles, or racing boots.</i>
3.	What is the minimum glove requirement?	<i>Gloves must not be woollen, or have open backs.</i>
4.	What is the minimum head protection requirement?	<i>A full face helmet with visor.</i>
5.	Where can the accepted helmet standards be found?	<i>Regulation B11.1 of the current NatSKA Handbook.</i>
<b>C. Driving &amp; Racing</b>		
1.	Is driving permitted in the pits?	<i>No.</i>
2.	When can you go out onto the track?	<i>Only when told to do so by the paddock marshal.</i>
3.	In which direction can you drive on the track?	<i>Only in the direction of racing.</i>
4.	How do you re-enter Parc Ferme?	<i>Slow down, raise your hand, and come to a stop in the Parc Ferme area.</i>
5.	What do you do if your kart stops on the track and you cannot continue?	<i>Raise your hands in the air, look around you, and if it's safe and no kart is approaching, get out and pull your kart to the side of the track, preferably onto the verge.</i>
6.	When overtaking happens, who is responsible?	<i>The driver overtaking.</i>

7.	How do you recognise a novice on the track?	<i>By an additional yellow number plate on the rear of the kart, carrying a black letter N</i>
8.	How do you drive when approaching a novice?	<i>With care and consideration.</i>
9.	How many practice laps do you have to complete before racing?	<i>Three laps</i>
10.	How do you drive on the rolling lap?	<i>A steady pace, in grid positions. Leading karts must not drive so slowly as to make the following karts stall, or drive so fast as to spread out the field.</i>
11.	How is the start of the race signalled?	<i>By the green light signal or an appropriate flag (e.g. Green Flag or Union Jack Flag).</i>
12.	What is your precise reaction to the starting signal?	<i>Stay in your grid position and do not pull out of line until you are past the start line, then race.</i>
<b>D. Flags</b>		
1.	Black & White Chequered Flag	<ul style="list-style-type: none"> <li>• <i>This means – the end of race or practice session.</i></li> <li>• <i>Driver Reaction – Stop driving at racing speed, proceed slowly without unnecessary overtaking, and with caution, to the pits.</i></li> </ul>
2.	Yellow Flag (stationary)	<ul style="list-style-type: none"> <li>• <i>This means – Danger, incident ahead.</i></li> <li>• <i>Driver Reaction – Slow down sufficiently, ensuring control is kept. No overtaking.</i></li> </ul>
3.	Yellow Flag (waved)	<ul style="list-style-type: none"> <li>• <i>This means – Danger, major incident ahead.</i></li> <li>• <i>Driver Reaction – Slow down considerably. Be prepared to divert from racing line, or take other diverting action, including stopping if necessary. No overtaking.</i></li> </ul>
4.	Blue Flag (stationary)	<ul style="list-style-type: none"> <li>• <i>This means – another kart is catching you, to lap you.</i></li> <li>• <i>Driver Reaction – Be aware of possible overtaking move soon.</i></li> </ul>
5.	Blue Flag (waved)	<ul style="list-style-type: none"> <li>• <i>This means – another kart is trying to overtake you, to lap you.</i></li> <li>• <i>Driver Reaction – Be aware of possible overtaking move NOW.</i></li> </ul>
6.	Red Flag	<ul style="list-style-type: none"> <li>• <i>This means – race or session has been stopped.</i></li> <li>• <i>Driver Reaction – Stop driving at racing speed and proceed slowly without overtaking and with maximum caution to parc ferme or stopping location, obeying the marshal's instructions. Be prepared to stop should the track be blocked.</i></li> </ul>

7.	Green Flag	<ul style="list-style-type: none"> <li>• <i>This means – all clear (at the end of a yellow flag section). Also used to indicate section clear before the start of practice session or race.</i></li> <li>• <i>Driver Reaction – Should not restart racing until passing a post not showing the yellow flag</i></li> </ul>
8.	White Flag	<ul style="list-style-type: none"> <li>• <i>This means – a service vehicle or slow moving kart is on the circuit. The flag is waved to indicate the section of the track that the vehicle is in.</i></li> <li>• <i>Driver Reaction – Be aware of slow moving vehicle on the track.</i></li> </ul>
9.	Yellow Flag with Red Stripes (stationary)	<ul style="list-style-type: none"> <li>• <i>This means – track conditions are changing</i></li> <li>• <i>Driver reaction – Be prepared for loss of grip on the track ahead</i></li> </ul>
10.	Yellow Flag with Red Stripes (waved)	<ul style="list-style-type: none"> <li>• <i>This means – track conditions are changing immediately ahead</i></li> <li>• <i>Driver reaction – Be prepared for immediate loss of grip on the track</i></li> </ul>
11.	Black & White Flag split diagonally, displayed with driver's number	<ul style="list-style-type: none"> <li>• <i>This means – Warning to the driver of on-track behaviour</i></li> <li>• <i>Driver reaction – Bad driving, you may be Black-Flagged on further bad driving.</i></li> </ul>
12.	Black Flag displayed with driver's number	<ul style="list-style-type: none"> <li>• <i>This means – Final warning to the driver.</i></li> <li>• <i>Driver reaction – Enter Parc Ferme on the lap of receiving the signal and report to the Clerk of the Course. A penalty of exclusion may be enforced.</i></li> </ul>
13.	Black Flag with orange circle, displayed with drivers number:	<ul style="list-style-type: none"> <li>• <i>This means – mechanical failure for the kart number shown.</i></li> <li>• <i>Driver Reaction – enter Parc Ferme on the lap of receiving the signal, repair the defect and have the kart re-scrutineered before taking part in any further heats</i></li> </ul>
14.	Green Flag with yellow chevron	<ul style="list-style-type: none"> <li>• <i>This means – False Start.</i></li> <li>• <i>Driver Reaction – go on another rolling lap in grid formation.</i></li> </ul>
15.	Yellow/Black Quartered Flag (aka the Battenberg Flag)	<ul style="list-style-type: none"> <li>• <i>This means – the whole circuit is under Yellow Flag conditions.</i></li> <li>• <i>Driver Reaction – Slow down to a steady pace, as used on a rolling lap. All karts line up behind the Race Leader who acts as pace setter. No overtaking is allowed. The field stays in formation at reduced speed, as long as it takes to clear the obstruction or remove the hazard. When the Clerk of the Course is satisfied that the track is clear or the problem is resolved, the race will be resumed with a Green Flag at the Start/Finish line, and the withdrawal of the Yellow/Black flags around the circuit..</i></li> </ul>

<b>E. Marshalling</b>		
1.	If you are marshalling, what is it your duty to do if an accident occurs?	<ul style="list-style-type: none"> <li>• <i>Stay on the marshal post, and show the correct flag.</i></li> </ul>
2.	If an accident happens, what flag should be displayed and for how long?	<ul style="list-style-type: none"> <li>• <i>A waved yellow flag, from the start of the accident until it is cleared, and the track is no longer obstructed</i></li> </ul>
3.	If you are responsible for the yellow flag on your marshal post, which section of track should you watch the most?	<ul style="list-style-type: none"> <li>• <i>All of the section between your marshal post to just past the next one.</i></li> </ul>
4.	If a kart is left unattended off the track but near to it, should a flag be displayed, and if so, which flag?	<ul style="list-style-type: none"> <li>• <i>Yes, a waved flag should be displayed, especially if the kart is in a dangerous place such as the outside of a corner or near the racing line.</i></li> </ul>
5.	When and to whom should the blue flag be shown?	<ul style="list-style-type: none"> <li>• <i>To the driver of a kart who is being caught and overtaken by a much faster kart lapping them. It should be waved when the faster kart is about to pass, held stationary when they are farther back.</i></li> </ul>
6.	When and where should the green flag be displayed (if used)?	<ul style="list-style-type: none"> <li>• <i>At the marshal post after a post showing a yellow flag for an incident.</i></li> </ul>
7.	What positions should the marshals take up while being on the post?	<ul style="list-style-type: none"> <li>• <i>Marshal with the yellow flag – face the direction of traffic towards the next marshal post.</i></li> <li>• <i>Marshal with green and blue flags – face towards the oncoming traffic.</i></li> <li>• <i>Marshals should stand facing each other, not back to back. The marshal facing the traffic should always be aware of traffic approaching the post and be able to warn or pull their partner out of the way in an emergency.</i></li> </ul>

## **Appendix I: Extracts from Motorsport UK Yearbook 2020**

Alteration to Supplementary Regulations:

No alteration or addition may be made to the Supplementary Regulations after the commencement of the period for receiving entries unless:

A: Motorsport UK and all competitors already entered agree in writing to the alteration; or

B: The Stewards of the meeting so decide for reasons of safety or force majeure.

C: Where a Championship Permit has been issued, Championship Sporting and Technical regulations may not be amended after publication unless Motorsport UK and all competitors registered for the Championship agree in writing to the alteration. Such amendments must be circulated to all registered competitors, championship Stewards, Eligibility Scrutineer, Clubs organising Rounds of the Championship and to Motorsport UK.

D: Championships exempt from registering with Motorsport UK do not need to comply with (c) above.



## NatSKA Appendix J

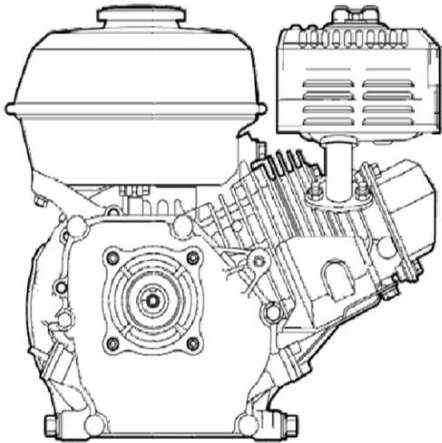

### 1. GENERAL

The scrutineer will pay special attention to ensure that the finish of all components match those of the standard unit and reserves the right to compare any part from competitors' engines directly with a standard part as supplied by Honda (UK). Unless competitors have gone out of their way to source alternative parts, their engines should automatically comply with this rule. Furthermore, competitors should note that the term "standard" refers not only to the components used but also to the number used, their position and function and the manner in which the engines are assembled.

Please remember that save for the changes specifically mentioned in these regulations the engines must be completely standard unmodified, and that all components will remain in place unless this document specifically states that they are allowed to be removed. No specific coating procedures are allowed on any internal or external surface of the engine. Carbon or gasket residue removal must be achieved by use of chemical agents only, to preserve original finishes, which must be apparent over the complete machined area (see Appendix 2). The fasteners on the engines may be drilled for the purposes of lock wiring. Replacement of external fasteners with non-Honda fasteners is only permitted when the replacement fastener improves safety or when the standard Honda fastener is not readily available. A thread recovery procedure is acceptable providing that the system and replacement fixing used are of no different size or pitch to the original and therefore offer no mechanical advantage over the original fixing, or alter the position of the original fixing.

### 2. DEFINITIONS

#### 2a. The standard, unmodified component

This means that the component has not had its substance altered in any way. It has had no material removed from it or added to it. It will be of the same, original material. Where appropriate, it should have the manufacturer's original manufacturing process or machining marks on it. It is the component defined as being applicable to the particular engine type.

#### 2b. Engine types

The original QHQ4 engine, to engine number 7664037, shall in this document be called the K engine. The QHQ4 engine from engine number 7664037 onwards shall in this document be called the E engine. The QHQ4 engine with suffix T, from engine number 1000000 onwards shall in this document be called the T engine. This will also include all unified specification engines (GX160UT1 QHQ4 and QHG4). GX160UT2 QHQ4 and GX160RT2-QHG4 engines (T2) will be eligible, with exceptions as notified in the following document.

#### 2c. Legality limit

In general terms, and where not clarified or qualified elsewhere in this document, the legal limit for eligibility purposes shall be deemed to be the service limit as specified by Honda, (current at April 2015), Service manual for the particular engine. (<http://www.honda-engines-eu.com/en/welcome.html>)

COMPONENT BY COMPONENT

3. The fuel tank

It is strongly urged that the engine's integral fuel tank be removed. If this is done then the engine must be fitted with a suitable cover. A standard centrally-mounted fuel tank should then be used, unmodified and this tank and its mounting must be in accordance with manufacturer's instructions. The capacity of this tank must not exceed 7.5 litres, if used for endurance events. Ballast may be added to the tank in order to maintain the maximum capacity. In this instance the kart may be fitted with a pulsed fuel pump(s), which will take a vacuum feed from either the governor rod hole or one drilled in the inlet manifold, tapped to accept a vacuum fitting. Fuel pipes must take a direct route to the carburettor and be safely secured. An extra loop of fuel pipe may be used as a return feed to the tank. One in-line fuel filter of nominal capacity per engine may be fitted, whose dimensions do not exceed circumference of 10cms and length (excluding stubs) of 5cms.

4. Exhaust

The standard exhaust must be used but a unit modified and sealed by an *Agent* may also be used. In this case, the unit will bear a seal applied by an *Agent* and it is the competitor's responsibility to ensure this seal is in place at all times. At any time the modified unit on the engine can be exchanged with one held by the scrutineer, who will then send the competitor's

exhaust back to an *Agent* for inspection. If this unit is found to have been tampered with in any way, then the competitor will be penalised retrospectively. No other repair or modification is allowed. Exhaust, Part No 18310-ZH7-V90 or 18310-Z4M-000 can also be used, and modified as above.

The *Agents* currently are: Focus Racing (0178 737 6655) and 7Kart (0192 083 1000)

The heat shield should be in place at all times. Where the original fixings have failed, they can be replaced with a rivet-type thread repair, which can alternatively be welded, in original position.



5. Carburettor

The T1 carburettor must only be used on the T1 engine type, and the T2 carburettor on the T2 engine type, both standard and unmodified. However all carburettors are subject to normal dimensional criteria. Overall length (manifold face to airbox face) is 53.9mm min and bore go / no go gauge is 13.2mm / 13.3mm. Pilot jet size 35 only, the mixture screw tang can

be removed. The T1 has 140 stamped on the throttle valve and four small holes just below the mixture screw point. The T2 has 150 stamped on it, with only three holes at the same point. (see Appendix note 1). When used as a Cadet engine, only the official ABkC restrictor plate (which may be de-burred) must be fitted between the carburettor and insulator, and have an opening of no more than 16mm diameter (see p.8).



A 2mm hole may be drilled in the tag on the restrictor for the purpose of affixing an official seal. This restrictor is not permitted in Senior engines.

6. Permitted main jets

size 68 (PN 99101-ZF5-0680)                      size 70 (PN 99101-ZF5-0700)

size 72 (PN 99101-ZF5-0720)                      size 75 (PN 99101-ZF5-0750)

Emulsion tube must be either part number 16166-ZH8-W50, 16166-ZH-810 or 16166-Z4M-922 (see drawing 1 in Appendix 1). The throttle-actuating arm can be modified to accept an actuating rod onto the throttle butterfly, a method of mounting a throttle actuating cable and a method of mounting a throttle return spring only.

7. Carburettor air box

Must be standard unmodified. The additional silencer, part number 17235-ZE1-831 may be used.

8. Air filter

The original air filter, if used, must have the base washer in place, it can have it's paper or foam or both removed. Alternatively it can be omitted completely or be substituted for another filter. In any case, the plastic outer cover must remain as standard, unmodified and fixed securely in its original position.

9. Spark plugs

Must be standard unmodified from the following list only, no other can be used. The standard Honda resistor spark plug cap - as supplied with the engine - must be used where a non-resistor spark plug is used, otherwise plug cap is free.

Permitted spark plugs

NGK	BPR6ES	BP6ES	BP5ES	BPR5ES
Nippondenso	W20EP-U	W20EPR-U	W16EP-U	W16EPR-U

10. Bodywork / ducting

All of the engine bodywork and ducting must be standard unmodified except for the drilling of a small hole to accept one end of a throttle return spring or security fixing. The pull-cord mechanism must be standard unmodified, although the pull-cord starter may be rotated on its standard mounting holes. All or any of the bodywork / ducting can be painted or chromed.

11. Rocker cover

Rocker cover must be standard unmodified, although it may be painted or chromed. Its valve must be present and in working order. The breather pipe must be in position and intact, of suitable length that it is securely fixed in both the rocker cover and the outlet of the airbox, and have no perforations or leakage points. Cover interchangeable between all engine types.

12. Valve Gear

The valve rocker studs must be standard unmodified. On the T1 engine only, the inlet valve collet (PN 14771-ZE1-000) may be replaced with an exhaust valve collet (PN 14773-ZE1-000) and an exhaust valve rotator (PN 14781-ZE1-000). If this modification is performed to the inlet valve, it is permissible to fit one 8mm washer between the cylinder head and the base of the valve rocker post to raise the post and ensure that the adjuster locknut sits on a full thread. The valve spring used must offer no mechanical advantage over a standard GX140 valve spring (PN14751- ZE1-000) i.e. a force of 5 kg will compress the spring to less than 25mm overall length, or a spring which offers no mechanical advantage over a standard QHG4 spring (PN 14751-ZH8-9400) i.e. a force of 8 kg will compress the spring to less than 18.5mm overall length. Valve rockers, cam followers and pushrods must be standard unmodified.

13. Valves

Valves will be standard unmodified. Valve-seat grinding and cutting is allowed, to the single

standard profile only (45°) and 30° cut to restore seat width, as specified in the latest Honda manual for the engine type. Valves of T1 and T2 engine are not interchangeable.

25mm	Inlet valve*	26mm
24mm	exhaust valve*	23mm
62.2mm	exhaust valve length*	63.7mm

**14. Cylinder head**



Will be standard unmodified and measure a minimum of 73.98mm from the rocker cover gasket face to the cylinder head gasket face. Ports must be standard unmodified. The standard de-burring marks and sharp edges should always be present. A maximum measurement of 29.25mm (inlet) and 28.25mm (exhaust) must be present between the cylinder head gasket face and the land surrounding the valve guide (see drawing 4 in appendix 1). Cylinder head of T1 and T2 are not interchangeable.

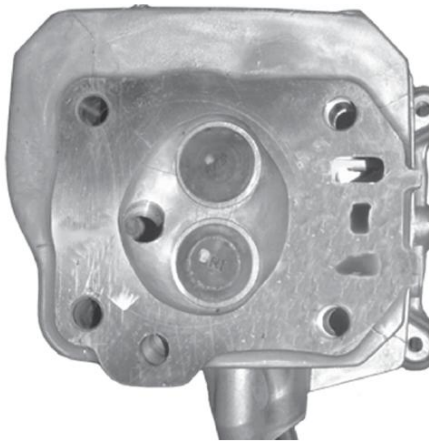

**K**



**T1**



**T2**

**15. Head gasket**



Must be standard unmodified and will at all times have a minimum thickness at all points of 0.95mm when used on K, E and T1 engines. Alternatively these engines can use 4 off gasket part number 12251- ZLO-003 which, when measured together at the sealing ring, must have a minimum thickness of 0.95mm. The T2 engine will use one off



part number 12251-ZLO- 003 which, when measured at the sealing ring, must have a minimum dimension of 0.28mm.

**16. Piston**

The dished piston must only be used with the cylinder head from the K type engine. The flat-top pistons are interchangeable between the E and T1 type engines only and must not be used in the K type engine or with the K type head. Piston rings will be standard unmodified. Only standard size rings, (marked 1R, R, T, 1T, NT, 1N/T or N on top ring) can be used. Either the

single or three-piece oil control ring can be used on all engine types. The rings must always be free in their grooves to function as designed. T1 and T2 pistons are not interchangeable. The T2 piston is shorter and has an additional curve under the oil ring. The top two piston rings are visually similar to the T1 but the oil control ring is thinner (2mm as against 2.5mm on the T1) and the ring groove in the piston is correspondingly smaller.



**Early T1**



**Late T1**



**T2**

**17. Connecting Rod**

The standard unmodified unit is interchangeable between K, E and T1 engine types. The connecting rod from the T2 engine must also remain standard, unmodified but will not fit other engine types on its own (but see also section 18).

158gr	Piston weight*	140gr
43gr	piston pin weight*	41gr
23.5mm	piston height*	21.4mm
See Appendix 3	con rod length	See Appendix 3
119gr	con rod weight*	123gr
7mm	con rod bolt*	6mm

**18. Crankshaft**

The governor gear can be removed. The position of the cam gear wheel is free. The standard key must be used on all engine types, but may be modified in accordance with item. The crankshafts are interchangeable between K, E and T1 engines only. You cannot transpose complete crank, rod and piston assemblies between T1 and T2 engines. In all instances, the final stroke must not exceed 45.1mm. The T2 crank may be used as a replacement in the T1 engine, but it is not permitted to use the T1 crank in the T2 engine.



### 19. Flywheel

The flywheel must be standard unmodified and have a minimum weight of 2.2kgs. The T1 and T2 flywheels are not inter-changeable. The key may be reduced in width or otherwise modified,



but not omitted. The ignition timing must be set/ checked with the engine at TDC, and the ABkC-marked template tool in place. The edge of the magnet must not intrude into the split marking the go (✓) and no-go (✗) area of the template (for the particular engine

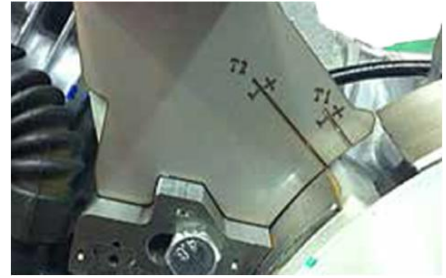

type).

If the output shaft keyway and throw of the crankshaft are aligned then the ABkC-marked location tool can be used to assist with the setting. For accuracy, the crankshaft must be rotated against the location tool in a clockwise direction (flywheel side) before the reading is observed on the template tool. The standard unmodified fan must be used, with all fins in place.

If the output shaft keyway and throw of the crankshaft are misaligned then the location tool cannot be used and in this instance the engine must be positioned at TDC using piston-stop or DTI method and the ABkC-marked template tool used as above.

### 20. Ignition coil

The ignition coil (including ignition lead) will be the standard unmodified unit and is interchangeable between all engine types. The coil mounting bolts must be standard unmodified and use the original mounting positions (see also section 23, welded repairs and dimensions in Appendix 3).

### 21. Camshaft

The standard unmodified camshaft must be used, the service limits are 27.65mm for the exhaust and 27.60mm for the inlet lobes(T1) and 27.45mm for both lobes (T2). The K, E, and T1 engine can only use the T1 camshaft, the T2 engine can only use the T2 camshaft. The inlet profiles are different between T1 and T2, with the T2 having a longer duration. The difference is easily identifiable with profile gauges or by measuring the open period.

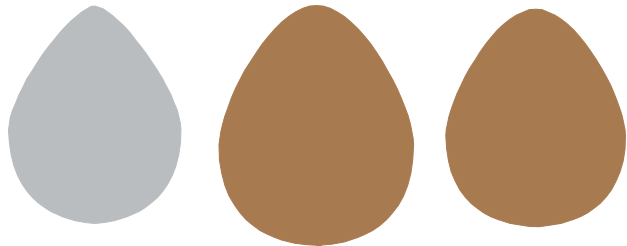

### 22. Push rods

The steel push rods of the T1 have been replaced with thicker aluminium units for the T2. The pushrods are not interchangeable between T1 and T2.



### 23. Crankcase

The crankcase can only be modified by the removal of the governor mechanism and in all other



respects must be standard unmodified. If completely removed, the hole in the crankcase must be sealed to prevent oil leakage (unless a suitable pulse take-off is used). The crankcase bearings and seals must be standard unmodified.





The bore must be standard only, service limit 68.165mm at all points of the bore. No sleeving or surface material change to the cylinder bore is allowed but honing is permitted. The cylinder mating face must always have the manufacturer's original finishing marks visible. The deck height must be 45.20mm  $\pm$  0.3mm (read between the cylinder mating face and the cast face of the piston, in line with the



piston pin, with the piston at BDC). Carbon removal is allowed as describe previously. (See drawing 2 & 3 in Appendix 1).

When measuring a K type engine, 1.3mm should be added to the obtained reading, to accommodate the dish in the piston.

Welded repairs are allowed to the engine mounting area at the crankcase base and additionally to one (only) of the ignition coil mounting posts, provided that this does not change the position or thread size of the post. No other welded repairs are permitted.

#### 24. Crankcase side cover

Must be standard unmodified and positioned with both standard, unmodified dowels in place. T1 and T2 side covers are interchangeable.

#### 25. Gaskets

All gaskets must be standard unmodified. Where there is any doubt about the eligibility or suitability of a particular gasket it should be compared with a new item from the manufacturer.

#### 26. Clutch

A dry, air-cooled centrifugal clutch of Noram, Horstman, Magnum, Maxtorque 1600 or 4000 series type (or any other clutch subsequently introduced which satisfies the same criteria), must be used to transmit the drive. The clutch should be in standard form (as supplied), be incapable of adjustment in position and have a maximum engagement speed of no more than 2,500 rpm engine speed. For clarification, shoe and drum type clutches only are permitted, plate clutches are not allowed (see Appendix 3).

### NOTES

Unless otherwise stated T1 component on left,  
T2 on right

Measurements marked \* are nominal, and only for guidance in determining differences between engine types. Other dimensions are absolute for scrutineering purposes.

# Appendix 1



PN 16166-ZH8-W50

PN 16166-ZH8-810

PN 16166-Z4M-922

Drawing 1

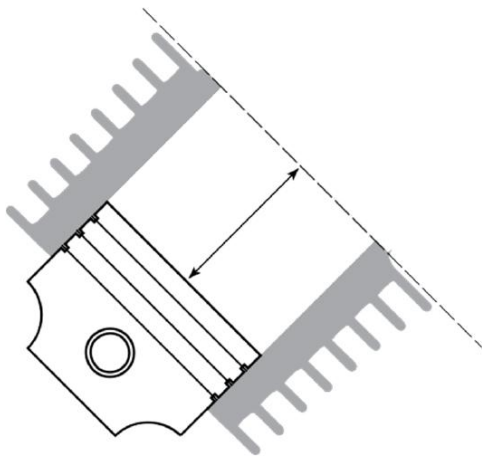

Drawing 2

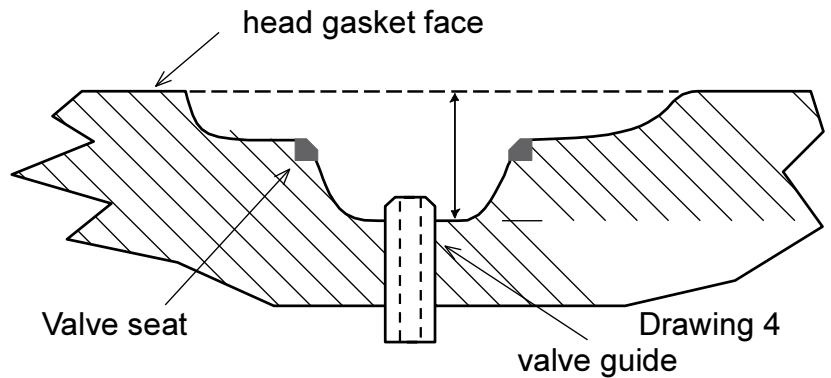

Drawing 4

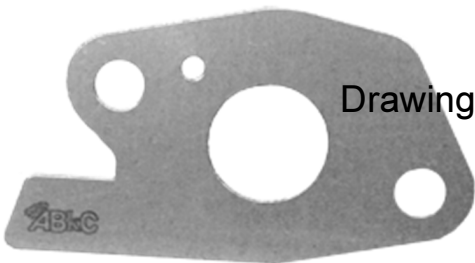

Drawing 3

Official ABkC restrictor plate

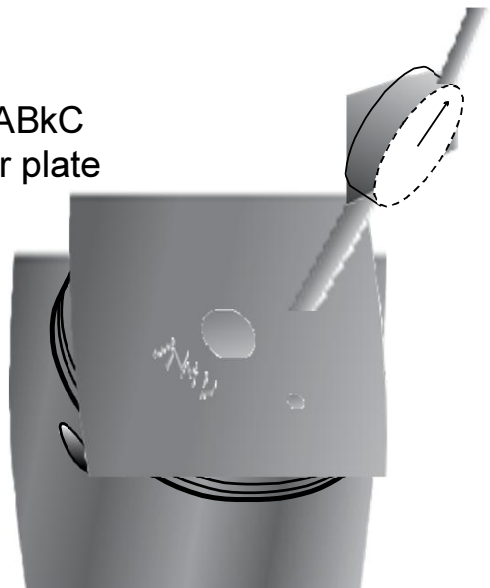

## Note 1

In all the carbs the bore is cast, not machined, and therefore can be a little out of true. If measuring this bore, it is safest to use a semi circular gauge, rather than a flat plate gauge.

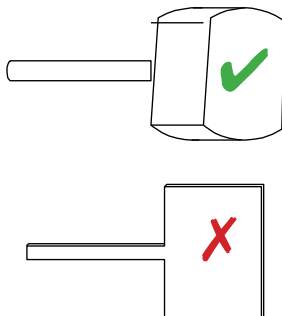



## Appendix 2

The original manufacturer's finish. The inspected engine might not be as bright or so distinct, but the patterning must be apparent over the complete machined area.

**A typical deck face**

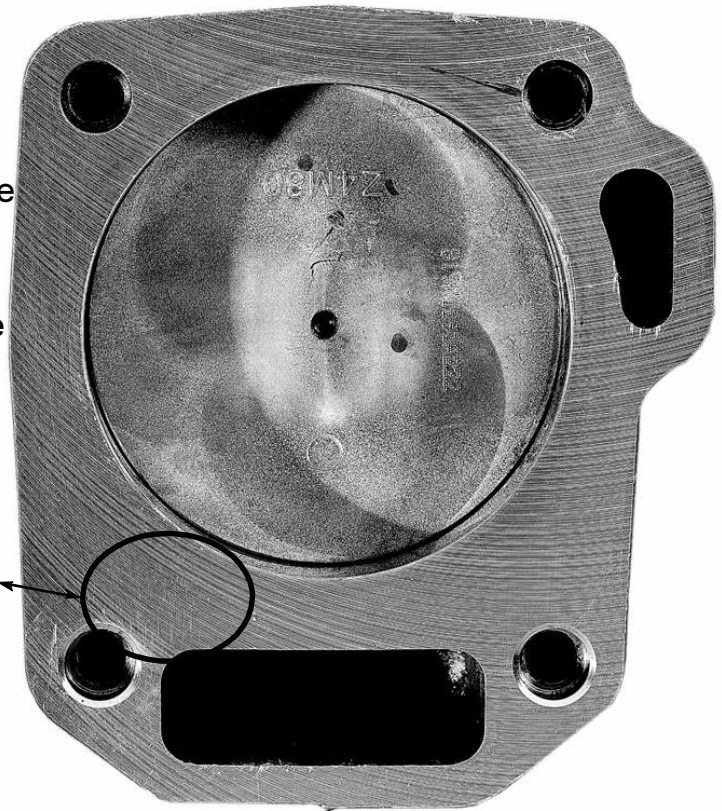
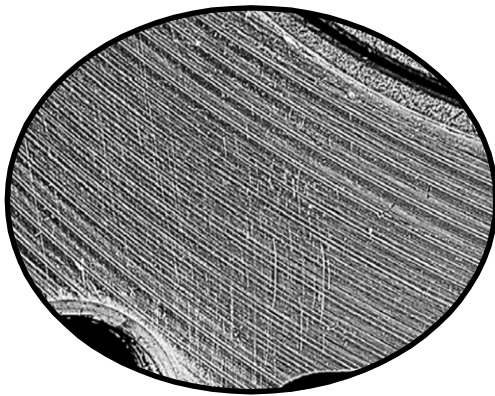

These lines might flow in different directions from engine to engine, or appear to originate or rotate from different points.

### Note 2

The finish will always look like this in a new engine, engines with "age" should be observed accordingly. This finish will never wear away on its own!

**A typical cylinder head face**

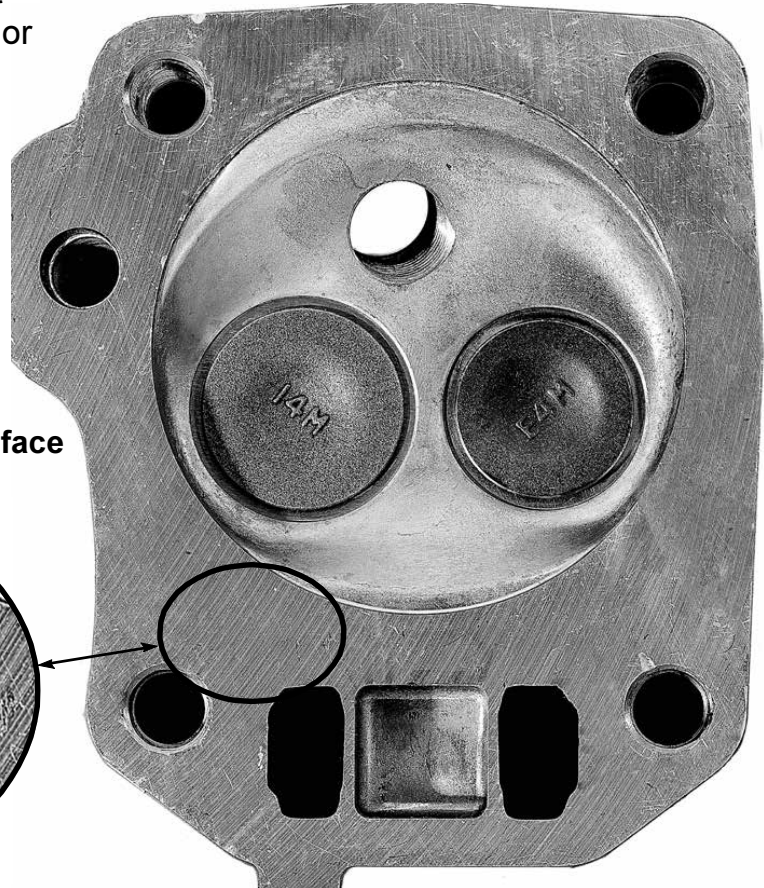
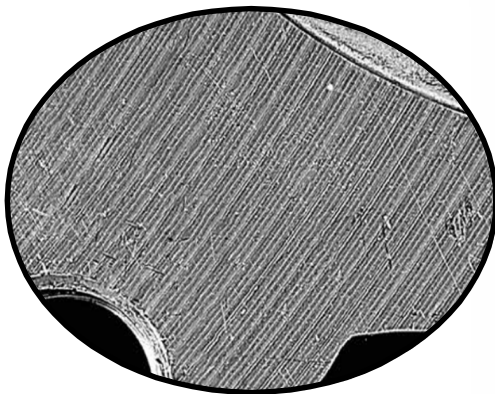

# Appendix 3

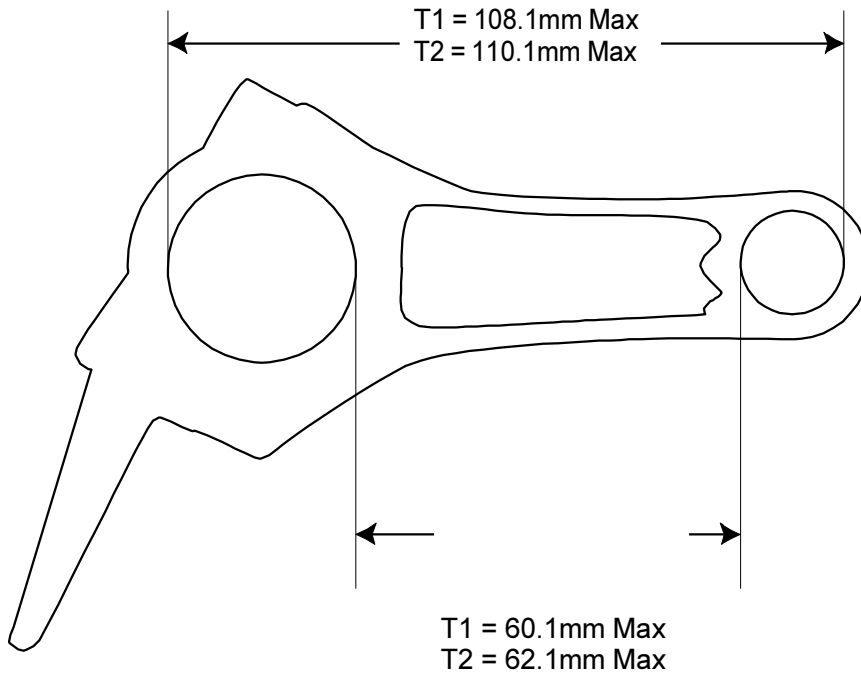

Connecting rod maximum dimensions

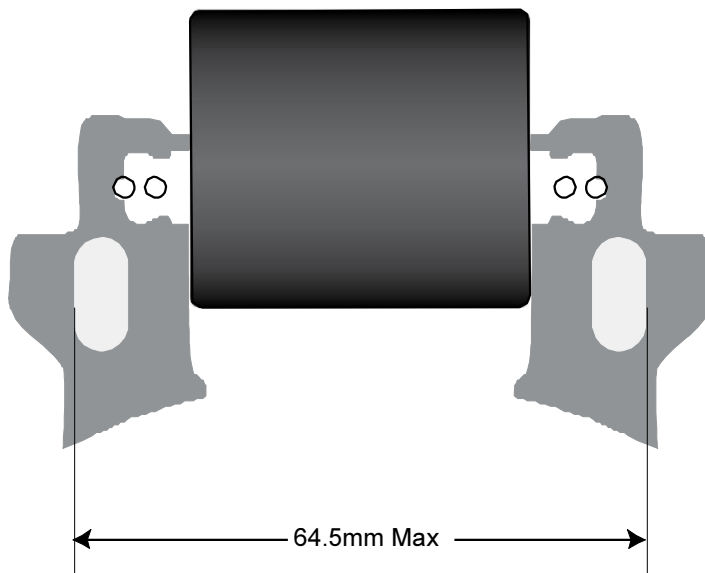
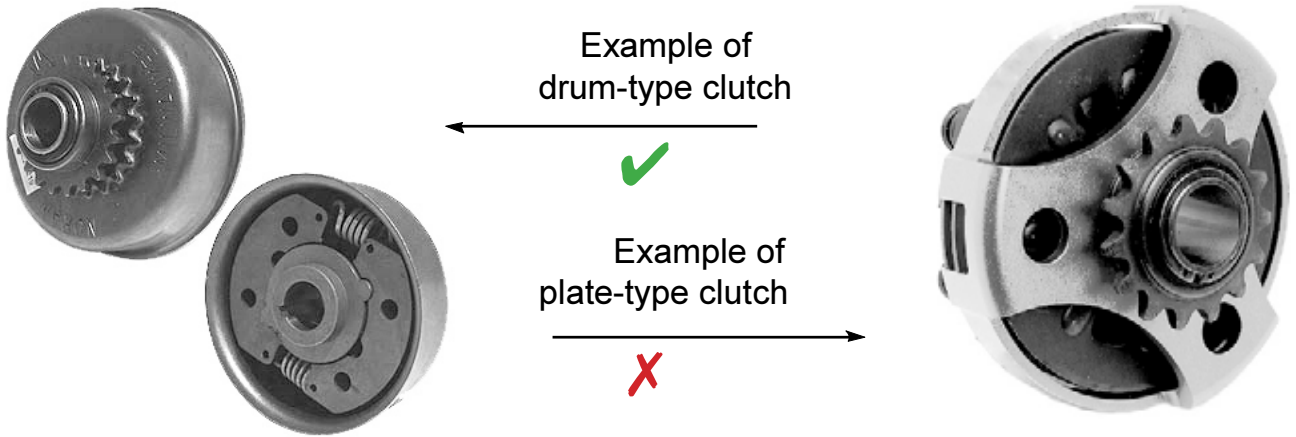

Maximum dimension, ignition coil mounting plate

**Appendix L: Suggested Template for Bumper Gauge**

Not to Scale

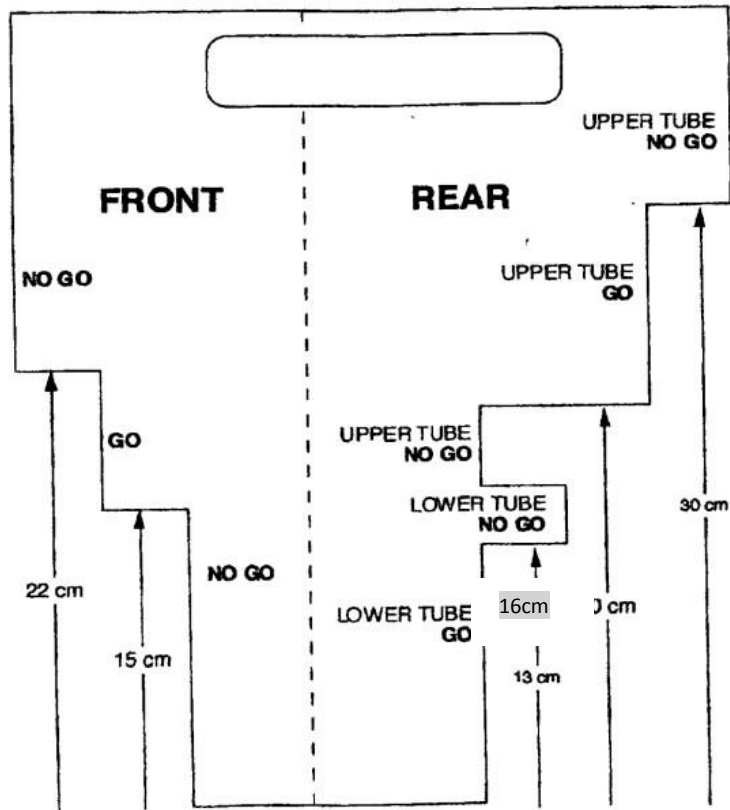

**Appendix M: Bumpers**

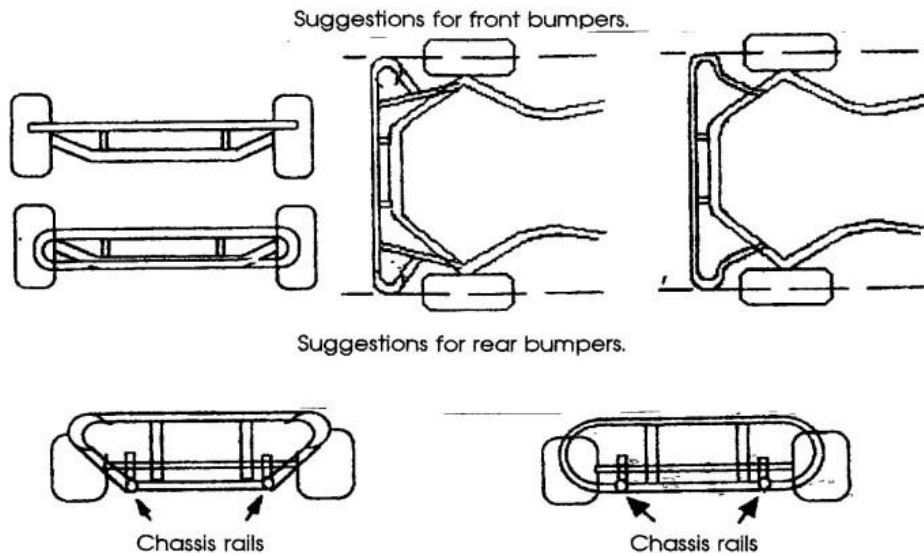

NOTE: All external radii of rear bumpers when viewed from behind must exceed 50 mm.

NOTE: Bolts and other fixing devices must not protrude beyond the outer face of front or rear bumpers.

## Appendix N: NatSKA Event Scoring System

**Sprints scoring** – points counting towards final score:

Contributory Heats	1 <sup>st</sup>	= 0 points	
	2 <sup>nd</sup>	= 2 points	
	3 <sup>rd</sup>	= 3 points	
	4 <sup>th</sup>	= 4 points	
	Etc.		
	Non finish		= grid
	Non start		= grid +1
	Disqualification or exclusion by C of C		= grid +2
	Penalty by C of C		= loss of up to 5 places

Events may be run where either all heats count or only a set number of the total number of heats run will count towards the final score. The number of heats to count may be varied but the same basic principle applies. Any variation to the principal should be posted prior to the event. Where heats are dropped the worst will be discarded.

Any kart penalised, excluded or disqualified from a heat must use those points in its final score and they may not be dropped.

For any technical exclusion given by the Clerk of the Course, the kart is given the points equivalent to DNF, which must then be used in its final score and may not be dropped, except where the Chief Scrutineer and/or Clerk of the Course deem the offence to be both minor and having provided no significant performance benefit.

In the event of a tie:

- 1) the points from the discarded heat will be used in determining the score, if still a tie then
- 2) the next worst heat scores are compared (the better score taking the higher place) and so on until all heat scores have been compared, if still a tie, then
- 3) the two drivers fastest heats through the day are compared to identify the driver with the quickest lap (where timing information is available). If it is still a tie then, it is a tie.

### Enduro scoring

The highest number of laps recorded for a kart during a specified period determines the positions in descending order, i.e. highest = 1<sup>st</sup>, next highest = 2<sup>nd</sup>, etc. Penalty by C of C = up to 5 laps. Disqualification = exclusion from results.

Driver changeover regulations will be specified in SR's.

Where a team is involved in a changeover at the signal for the end of the event that kart should be allowed to complete the interrupted lap. Where a kart becomes incapable of continuing then its number of recorded laps up to that point shall be its score. If the final result produces a tie then the result shall be a tie.

**Special Meeting** - where appropriate or deemed desirable race organisers may run special meeting based on the heats and a final.

### National Sprint Championship

The format of the NatSKA National Sprint Championship will be as follows:

#### 1. NatSKA "S" Plate

The National Sprint Championship meeting ("the Nationals") will take place over two days and will comprise of six heats, five to count. Each Class Winner will be presented with the National Sprint Champion perpetual (as per B22.3) trophy and will be entitled to carry

the National Sprint “S” Plate in that Class to 31<sup>st</sup> August of the following year (as per D5.1). Trophies will be awarded in accordance with B22.1. A minimum of two entrants are required in a class for the “S” plate to be awarded.

## 2. **NatSKA Race Numbers**

The results from “the Nationals” meeting will be added to the Drivers best six results in that Class from the previous 12 months (not including the previous year’s National Sprint meeting) and from which the top-ten Championship positions will then be determined. Results from a meeting in which a competitor received a race meeting exclusion are not included within the Championship points totals (Excluded result can be dropped).

The only compulsory event in this Seven-round mini Championship will be the National Sprint Championship meeting itself.

The top-ten placed Championship winners will be presented with their race numbers at the National Sprint Championship meeting and will be entitled to carry their numbers in that Class through to 31<sup>st</sup> August of the following year (as per D5.7)

For the purposes of the Championship table, points will be awarded: 100 points to the winner, 98 to second place and thereafter reducing by 2 points for each subsequent place. In the event of a tie with drivers finishing the Championship on equal points, the results of the National Sprint Championship meeting will be used to determine the final place positions.

With respect to drivers moving up from Class 11 to Class 12 during the course of the season, for the purposes of the Championship, the drivers best six results will primarily be determined by their results in Class 12; and only being supplemented by their best results from Class 11 if they have not undertaken six meetings in Class 12 prior to the Nationals.

## **Appendix O: Memorandum, Articles and Certificates of Association**

The Companies Acts 1985 and 1989

### **PRIVATE COMPANY LIMITED BY GUARANTEE AND NOT HAVING A SHARE CAPITAL**

#### **MEMORANDUM OF ASSOCIATION of NatSKA Limited**

1. The Company's name is NatSKA Limited
2. The Company's registered office is to be situated in England and Wales.
3. The Company's objects are:
  - (A) to encourage the formation and development of karting in schools and recognised youth groups, to encourage the development of design and technical skills as a necessary branch of education; to provide members with information advice and assistance on matters connected with karting and kart construction; to standardise on karting procedures and choice of engine; to organise events both locally and nationally as from time to time determined and in the furtherance of these objects, but for no other purpose, to raise funds by such ways and means as the company from time to time shall decide, provided that the company shall not undertake any permanent trading activities in raising funds for its primary objects; and as incidental or conducive to any of these objects the Company shall have the following powers:
  - (B) to let out or take on hire as places of assembly, display centres or otherwise any part or parts of any land or buildings and in such divisions and manner as may seem expedient;
  - (C) to edit print and publish books papers reports guide books periodicals circulars articles and other matters whatsoever;
  - (D) to hold conferences seminars meetings lectures courses and discussions;
  - (E) to employ and remunerate all such officers, advisors and servants as may be required for the purposes of the Company and to grant pensions and retirement benefits to or for employees or former employees of the Company and to the widows children or other dependants of deceased employees who are in necessitous circumstances and to pay or subscribe to funds or schemes for the provision of pensions and retirement benefits for employees of the Company their widows children and other dependants;
  - (F) to borrow or raise funds for the purpose of the Company on such terms and on such security (if any) as may be thought fit;
  - (G) to establish promote form and support or aid in the establishment promotion formation and support of any other charitable associations or institutions and to subscribe or guarantee money for charitable purposes in any way connected with or calculated to further the objects of the Company;
  - (H) to raise funds and to invite and to receive subscriptions endowments grants (whether government municipal or from any statutory or charitable body or otherwise) and donations (whether of real or of personal property) and devices and bequests for all or any of the purposes aforesaid and generally to manage invest and expend all monies belonging to the Company;
  - (I) to invest the monies of the Company not immediately required for its purpose in or upon such investments securities or property as may be thought fit subject nevertheless to such conditions (if any) that may for the time being be imposed or required by law and subject also as hereinafter provided;
  - (J) to sell or co-operate with others in selling terms any postcards souvenirs novelties promotional items articles and gift merchandise for the purpose of promoting the objects of the Company;
  - (K) to establish operate and carry on or to co-operate with others in establishing operating and carrying on in any building which the Company is interested the supply thereof of food and drink and other refreshments by way of sale provided always that the amenities mentioned in this paragraph shall be provided only for the purposes of attending a performance meeting or function sponsored by the Company;
  - (L) to make representations at public enquiries appeals or in such other ways as shall appear necessary from time to time in furtherance of the objects of the Company;

- (M) to employ and pay architects engineers construction experts accountants solicitors chartered secretaries and other professional persons clerks and other staff for the purpose of fulfilling the objects of the Company;
- (N) to do all such things as are necessary to the attainment of the above objects or any of them.

4. The income and the property of the Company whencesoever derived shall be applied solely towards the promotion of the objects of the Company as set forth in this Memorandum of Association and no member shall have any personal claim on any property of the Company and no portion thereof shall be paid transferred or distributed directly or indirectly by way of dividend bonus or otherwise howsoever by way of profit to members of the Company provided always that nothing herein shall prevent the payment in good faith by the Company of a reasonable and proper remuneration to any officer or servant of the Company or to any member of the Company in return for any services actually rendered to the Company or interest on money lent or reasonable and proper rent for premises demised or let by any member to the Company but so that no member of the Committee of the Company shall be appointed to any salaried office of the Company or any office of the Company paid by fees and that no remuneration or other benefit in money or moneys worth shall be given by the Company to any member of such Committee except repayment of out of pocket expenses and interest on money lent or reasonable and proper rent for premises demised or let to the Company provided further that the provision last aforesaid shall not apply to any payments to any Company of which a member of the Committee may be a member and in which such member shall not hold more than one hundredth part of the capital and such member shall not be bound to account for any share of profits he or she may receive in respect of any such payment.

5. The liability of the members is limited.

6. Every member of the Company undertakes to contribute such amount not exceeding £10.00 as may be required to the assets of the Company if It should be wound up while he or she is a member or within one year after he ceases to be a member for payment of the debts and liabilities of the Company contracted before he or she ceases to be a member and the costs charges and expenses of winding up and for the adjustments of the rights of the contributors among themselves.

7. True accounts shall be kept of the sums of money received and expended by the Company and the matters in respect of which such receipts and expenditure takes place and of the property credits and liabilities of the Company and subject to any reasonable restrictions as to the time and manner of inspecting the same that may be imposed in accordance with the regulations of the Company for the time being such accounts shall be open to the inspection of the members. Once at least in every financial year the accounts of the Company shall be examined and the correctness thereof and of the balance sheet ascertained by one or more auditor of auditors qualified to act as auditor pursuant to the provisions of the Companies Act 1985.

8. If upon the winding up or dissolution of the Company there remains after the satisfaction of all its debts and liabilities any property whatsoever the same shall not be paid to or distributed amongst the members of the Company but shall be given or transferred to some other Company or charitable institution or institutions having objects similar to the objects of the Company and which shall prohibit the distribution of its or their income or property amongst its or their members to an extent at least as great as is imposed on the Company under or by virtue of clause 4 hereof such Company or institution to be determined by the members of the Company at or before the time of dissolution

I THE SUBSCRIBER TO THIS MEMORANDUM OF ASSOCIATION WISH TO BE FORMED INTO A COMPANY PURSUANT TO THIS MEMORANDUM OF ASSOCIATION

Name and address of subscriber:  
PHILIP CHARLES VIBRANS  
1 Ashfield Road  
Davenport  
Stockport  
Cheshire  
SK3 8UD

England

Dated: 15<sup>th</sup> May 1998

Witness to the above signature(s):  
NEIL EDWARD WAKEFIELD  
22 Stopford Street  
Edgeley  
Stockport  
Cheshire  
SK3 9HE

## **Appendix O: Memorandum, Articles and Certificate of Association Continued**

The Companies Acts 1985 and 1989

### **PRIVATE COMPANY LIMITED BY GUARANTEE AND NOT HAVING A SHARE CAPITAL**

ARTICLES OF ASSOCIATION OF NatSKA Limited

#### **INTERPRETATION**

1. In these Articles:

“the Act” means The Companies Act 1985

“the Seal” means the common seal of the Company

“secretary” means any person appointed to perform the duties of the secretary of the Company

“member(s)” shall have ascribed to it the meaning as defined in section 22 of the Act and means all members who pay a subscription to the Company and any such other individuals or organisations as shall be added or substituted in accordance with articles 3 and 4 hereof

“associate(s) means any individual company partnership or other organisation resident in part of the world

Expressions referring to writing shall unless the contrary intention appears become construed as including references to printing lithography photography and other modes of representing or reproducing words in a visible form. Unless the context otherwise requires words or expressions contained in these Articles shall bear the same meaning as in the Act or any statutory modification thereof in force at the date at which these Articles become binding on the Company. The regulations in Table C schedule to the Companies (Tables A to F) Regulations 1985 shall except where they are varied by or are inconsistent with the Articles apply to the Company.

#### **OBJECTS**

2. The Company is established for the objects expressed in the Memorandum of Association.

#### **MEMBERS**

3(a) The subscribers to the Memorandum of Association, Team Members as defined in Article 3(b) and such other persons as the Directors shall admit to membership shall be members of the Company. Every member of the Company shall either sign a written consent to become a member or sign the register of members on becoming a member. Regulation 3 of table C shall be varied accordingly.

3(b) “Team Members” shall be representatives of participating teams engaged in events and activities organised by the Company. A Team Member must be a qualified teacher, a recognized youth leader or an individual nominated by an appointed school headmaster and the governing body of a school or youth group and approved by the Board of Directors.

3(c) All Members must abide by the Company’s operating regulations as defined by the Board of Directors.



4. The Directors may from time to time admit any person organisation or body as an additional member and may at their discretion remove any such person organisation or body from the list of members.

### **GENERAL MEETINGS**

5. The Company shall in each year hold a general meeting as its Annual General Meeting in addition to any other meetings in that year and shall specify the meeting as such in the notices calling it and not more than 15 months shall elapse between the date of one Annual General Meeting of the Company and that of the next. Provided that so long as the company holds its first Annual General Meeting within 18 months of its incorporation it need not hold it in the year of its incorporation or in the following year. The Annual General Meeting shall be held at such time and place as the Directors shall appoint. All general meetings other than Annual General Meetings shall be called Extraordinary General Meetings.

6. The Directors may whenever they think fit convene an Extraordinary General Meeting and Extraordinary General Meetings shall also be convened on the requisition of three or more members or in default maybe convened by such requisitionists as provided by Section 368 of the Act. If at any time there are not sufficient Directors capable of acting to form a quorum any Director or any three members of the Company may convene an Extraordinary meeting in the same manner as nearly as possible as that in which meetings may be convened by the Directors.

### **NOTICE OF GENERAL MEETINGS**

7. An Annual General Meeting and a Meeting called for the passing of the Special Resolution shall be called by twenty one days notice in writing at the least and a Meeting of the Company other than an Annual General Meeting or a meeting for the passing of a special resolution shall be called by fourteen days notice in writing at the least. The notice shall be exclusive of the day on which it is served or deemed to be served and of the day for which it is given and shall specify the place the day and the hour of the meeting and in the case of special business the general nature of that business and shall be given in manner hereinafter mentioned or in such other manner if any as may be prescribed by the Company in General Meeting to such persons as are under the Articles of the Company entitled to receive such notices from the Company.

Provided that a Meeting of the Company shall notwithstanding that it is called by shorter notice than that specified in this article be deemed to have been duly called if it is so agreed:-

- a) In the case of a meeting called as the Annual General Meeting by all the members entitled to attend and vote thereat; and
- b) In the case of any other meeting by a majority in number of the members having a right to attend and vote at the Meeting being a majority together representing not less than 95% of the total voting rights at that Meeting of all the members.

8. The accidental omission to give notice of a meeting to or the non receipt of the notice of a meeting by any person entitled to receive notice shall not invalidate the proceedings of that meeting.

### **PROCEEDINGS AT GENERAL MEETINGS**

9. All business shall be deemed special that is transacted at an Extraordinary General Meeting and also that is transacted at an Annual General Meeting with the exception of the consideration of the accounts balance sheets and the reports of the Directors and Auditors and the appointments of and the fixing of the remuneration of the Auditors.

10. No business shall be transacted at any General Meeting unless a quorum of members is present at the time when the Meeting proceeds to business save as herein otherwise provided 50% of the members present in person shall be a quorum. If within half an hour of the time appointed for the Meeting a quorum is not present the Meeting if convened upon the requisition of members shall be dissolved in any other case it shall stand adjourned to the same day in the next week at the same time and place or to such other day and at such other time and place as the Directors may determine.

11. The Chairman if any of the Company shall preside as Chairman at every General Meeting of the Company or if there is no such Chairman or if he shall not be present within fifteen minutes after the

time appointed for the holding of the Meeting or is unwilling to act the deputy Chairman shall preside and if he shall not be present the Secretary shall preside and if the Secretary shall not be present the Treasurer shall preside and if the Treasurer shall not be present the Directors present shall elect one of their number to be Chairman of the Meeting.

12. The Chairman may with the consent of any meeting at which quorum is present (and shall if so directed by the Meeting) adjourn the Meeting from time to time and from place to place but no business shall be transacted at any adjourned Meeting other than the business left unfinished at the Meeting from which the adjournment took place. When a meeting is adjourned for thirty days or more notice of the adjourned meeting shall be given as in the case of an original meeting. Save as aforesaid it shall not be necessary to give any notice of an adjournment or of the business to be transacted at an adjourned meeting.

13. At any General Meeting a resolution put to the vote of the Meeting shall be decided on a show of hands unless a poll is (before or on a declaration of the result of the show of hands) demanded:-

- a) by the Chairman; or
- b) by at least two members present in person or by proxy; or
- c) by any member or members present in person or by proxy and representing not less than one tenth of the total voting rights of all the members having the right to vote at the Meeting.

Unless a poll is so demanded a declaration by the Chairman that a resolution has on a show of hands been carried or carried unanimously or by a particular majority or lost and on entry to that effect in the book containing the Minutes of the proceedings of the Company shall be conclusive evidence of the fact without proof of the number or proportion of the votes recorded in favour of or against such resolution.

The demand for a poll may be withdrawn.

14. Except as provided in Article 20 if a poll is duly demanded it shall be taken in such manner as the Chairman directs and the result of the poll shall be deemed to be the resolution of the Meeting at which the poll is demanded.

15. In the case of an equality of votes whether on a show of hands or a poll the Chairman of the Meeting at which the show of hands takes place or which the poll is demanded shall be entitled to a second or casting vote.

16. A poll demanded on the election of a Chairman or on a question of adjournment shall be taken forthwith. A poll demanded on any other question shall be taken at such time as the Chairman of the Meeting directs and any business other than that upon which a poll has been demanded may be proceeded with pending the taking of the poll.

17. Subject to the provisions of the Act a resolution in writing signed by all the members for the time being entitled to receive notice of and to attend and vote at General Meetings (or being corporations by their duly authorised representatives) shall be as valid and effective as if the same had been passed at a General Meeting of the Company duly convened and held.

## **VOTES OF MEMBERS**

18. Every Member shall have one vote either in person or by proxy. If a vote is given by proxy, the vote will only be valid for a proposal whilst it remains in the same unaltered state as when the proxy vote was submitted.

19. On a poll votes may be given either personally or by proxy.

20. The instrument appointing a proxy shall be in writing under the hand of the appointer or of his attorney duly authorised in writing. A proxy must be a member of the Company.

21. The instrument appointing the proxy and the Power of Attorney or other authority if any under which it is signed or a notarially certified copy of that Power or authority shall be deposited at the registered office of the Company or at such other place as is specified for that purpose in the notice convening the Meeting not less than forty eight hours before the time for holding the Meeting or

adjourned meeting at which the person named in the instrument proposes to vote or in the case of a poll not less than twenty four hours before the time appointed for the taking of the poll and in default the instrument of proxy shall not be treated as valid.

22. The instrument appointing a proxy shall be deemed to confer authority to demand or join in demanding a poll and is available from the Secretary.

23. A vote given in accordance with the terms of an instrument of proxy shall be valid notwithstanding a previous liquidation for dissolution of the principal or revocation of the proxy or of the authority under which the proxy was executed provided that no intimation in writing of such liquidation dissolution or revocation as aforesaid shall have been received by the Company at the office before the commencement of the Meeting or adjourned meeting at which the proxy is used.

## **DIRECTORS**

24(a) The Committee Members filling the roles of Chairman, Secretary, Treasurer, Membership and Licensing Director, Technical Director and Competition Secretary within the Company shall be deemed to be a Director. All other Committee Members shall assist the Directors.

24(b) Directors must be Team Members and/or persons who have been active in the running/organisation of NatSKA for a minimum of two years.

25. The maximum and minimum numbers of Directors shall be determined by the Company in General Meeting but unless and until so fixed there shall be no maximum number and the minimum number of Directors shall be one

## **POWERS AND DUTIES DIRECTORS**

26. The business of the Company shall be managed by the Directors who may pay all expenses incurred in promoting and registering the Company and may exercise all such powers of the Company as are not by the Act or these Articles required to be exercised by the Company in General Meeting but no regulation made by the Company in General Meeting shall invalidate any prior act of the Directors which would have been valid if that regulation had not been made

27. All cheques promissory notes drafts bills of exchange and other negotiable instruments and all receipts for monies paid to the Company shall be signed drawn accepted endorsed or otherwise executed as the case may be in such manner as the Directors from time to time by resolution determine.

28. The Directors shall cause Minutes to be made in books provided for the purpose:

- a) of all appointments of officers made to the Directors;
- b) of the names of the Directors present at each Meeting of the Directors and of any Committee of the directors;
- c) of all resolutions and proceedings at all meetings of the Company and of the Directors and of Committees of the Directors.

## **DISQUALIFICATION OF DIRECTORS**

29. The office of Director shall be vacated if the member:-

- a) becomes bankrupt or makes any arrangement or composition with his creditors generally; or
- b) becomes prohibited from being a Director by reason of any order made under Sections 295 to 300 (inclusive) of the Act; or
- c) becomes incapable by reason of mental disorder illness or injury of managing and administering his property and affairs; or
- d) resigns his office by notice in writing to the Company.

30. A Director notwithstanding that he or any person connected with him has an interest or duty which is material and which conflicts or may conflict with the interests of the Company may vote in respect of any Contract transaction or arrangement and may be counted in the quorum present at any meeting.

31. No Director shall be required to retire or vacate his office or be ineligible for re-appointment as a Director nor shall any person be ineligible for appointment as a Director by reason of his having attained any particular age.

32. The Company may by ordinary resolution of which special notice has been given in accordance with Section 379 of the Act remove any Director before the expiration of his period of office notwithstanding anything in these Articles or in any Agreement between the Company and such Director.

### **PROCEEDINGS OF DIRECTORS**

33. The Directors may meet together for the despatch of business adjourn and otherwise regulate their meetings as they think fit. Questions arising at any meeting shall be decided by a majority of votes. In the case of an equality of votes the Chairman shall have a second or casting vote. A Director may and the Secretary on the requisition of a member of the Directors shall at any time summon a meeting of the Directors.

34. The quorum necessary for the transaction of the business of the Directors may be fixed by the Directors and unless so fixed shall be at least 51% of the members for the time being of the Directors present in person.

35. The continuing Directors may act notwithstanding any vacancy in their body but if and so long as their number is reduced below the number fixed by all pursuant to the Articles of the Company as the necessary quorum of the numbers of the Directors the continuing members or Directors may act for the purpose of increasing the number of Directors to that number or of summoning a General Meeting of the Company but for no other purpose.

Name and address of subscriber:

PHILIP CHARLES VIBRANS

1 Ashfield Road

Davenport

Stockport

Cheshire

SK3 8UD

England

Witness to the above signature(s):

NEIL EDWARD WAKEFIELD

22 Stopford Street

Edgeley

Stockport

Cheshire

SK3 9HE

England

Dated: 15<sup>th</sup> May 1998

**Appendix O: Memorandum, Articles and Certificate of Association Continued**



**CERTIFICATE OF INCORPORATION  
OF A PRIVATE LIMITED COMPANY**

**Company No. 3570657**

The Registrar of Companies for England and Wales hereby certifies that  
NatSKA Limited

is this day incorporated under the Companies Act 1985 as a private company  
and that the company is limited.

Given at Companies House, Cardiff, the 27th May 1998

MRS E P OWEN

For the Registrar of Companies



C O M P A N I E S   H O U S E

HC007A

**Appendix P: Figure K6 – Motorsport UK Yearbook (Competitors and Officials) 2020**

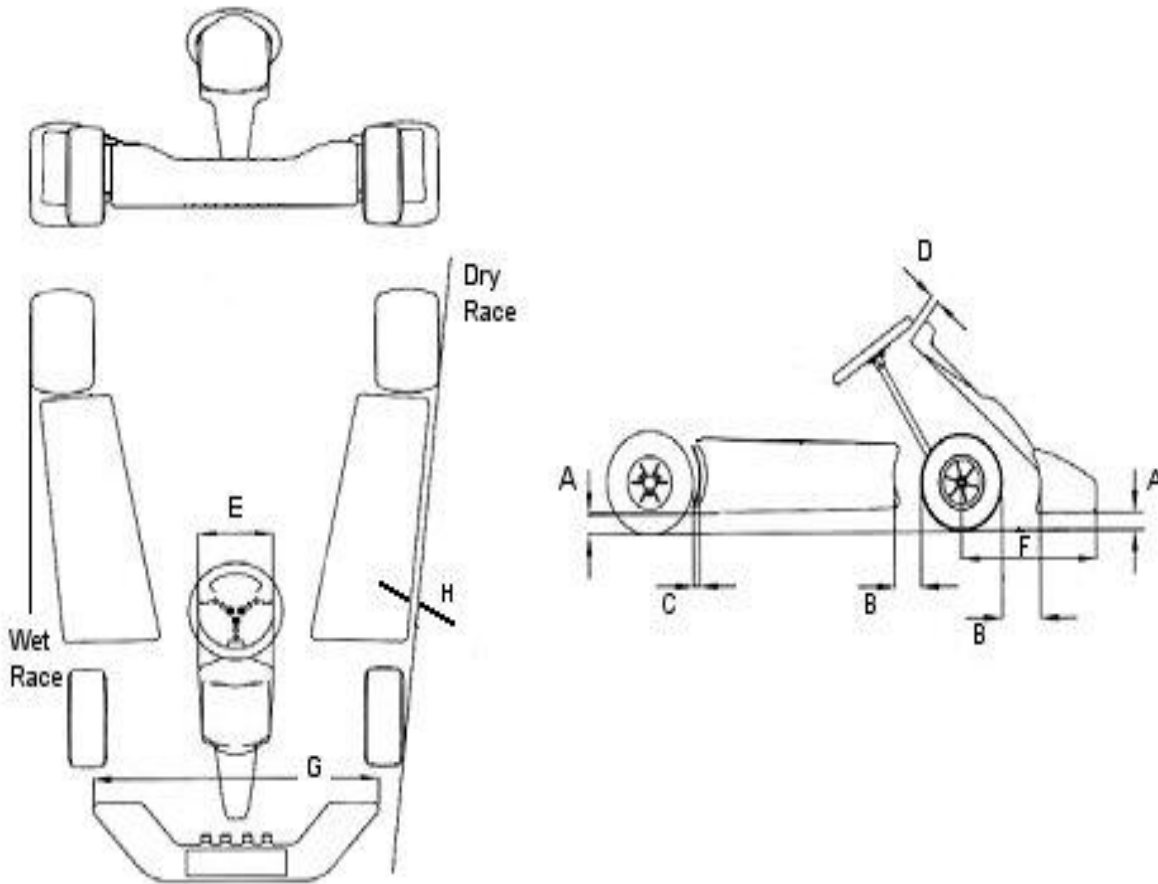

Code Letter	Short Circuit	Cadet	Limit
<b>A</b> (Drive onboard)	25mm	25mm	Minimum
	60mm	60mm	Maximum
<b>B</b>	180mm	150mm	Maximum
<b>C</b>	60mm	60mm	Maximum
<b>D</b>	50mm	50mm	Minimum
<b>E</b>	250mm	250mm	Minimum
	300mm	300mm	Maximum
<b>F</b>	680mm	500mm	Maximum
<b>G</b>	1000mm	700mm	Minimum
	External width of front track	1000mm	Maximum
<b>H</b>	40mm	40mm	Maximum
<b>I</b>	150mm	150mm	Maximum

## Appendix Q: Bolts To Be Drilled For Seals on Class 11, 12 and 13 Engines

### Honda GX160

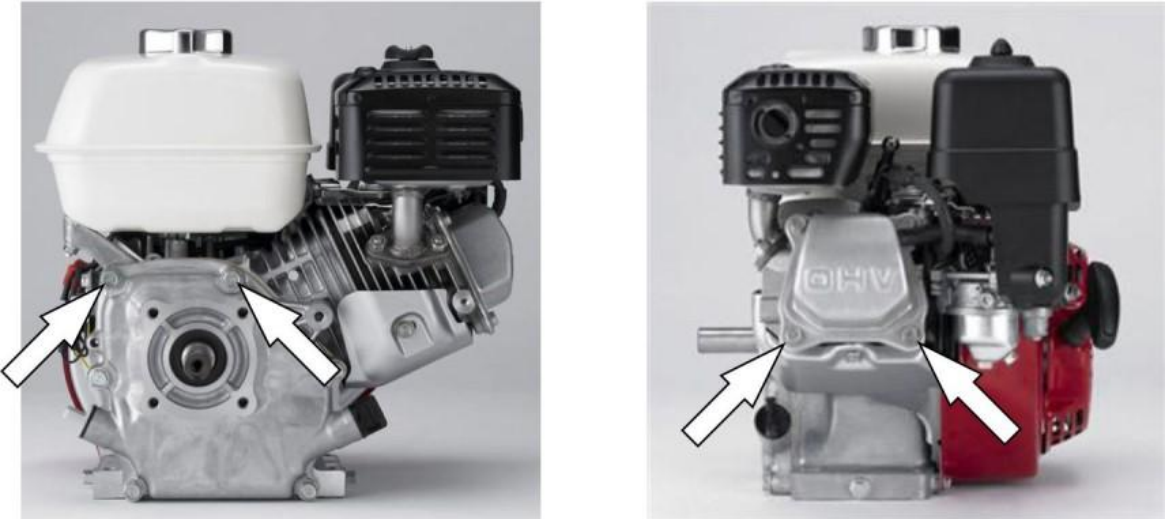

**Bolts indicated by arrows  
to be pre-drilled to allow  
lock wire sealing**

## Appendix R: Class 15 Regulations

1. Deleted.
2. Deleted.
3. EVO Type Ancillaries are allowed.
4. Intake Silencer: Type 1 or Type 2 may be used.

Type 1 must be used as supplied by Rotax for the FR125 Max engine unmodified, except for the bottom half of the air box, where the lug support ribs on the longitudinal side may be removed to allow fitting of the air box support bracket. It is also permitted for the air box lower half (type 1 only) to have a single 8mm maximum diameter hole positioned in a central location using the area of the injection mould marks as guide.

5. Radiator and Clutch sprocket are not required to be stamped with Rotax.
6. Any battery can be used provided it is of the same specification as originally supplied by Rotax; 12v / 6.5Ah, 12v / 7.2Ah or 12v / 9Ah.

## **Appendix S: Class 13 – 4 stroke high power**

### **Engine Type and description**

The engine is to be a Loncin G390F-P, and must be supplied through NatSKA. The engine and all of its components and ancillaries are to remain in entirely box stock form, with the following exceptions below;

- The fitting of an appropriate throttle linkage and return spring(s).
- Removal of the governor mechanism and oil alert switch.
- Removal of the onboard fuel tank, and fitting of an appropriate engine cover.
- Installation of a pulse pump feed to either crankcase (via tapped governor rod hole) or rocker cover.
- Two crankcase cover bolts, the rocker cover and flywheel cover fixings will need to be drilled to accept scrutineering seals. Standard bolts may be substituted with pre-drilled replacements in scrutineering. The location as to where seals are required are shown at the end of this appendix.

### **Onboard fuel tank**

This can be removed and replaced by a suitable engine cover. A standard fuel mounted tank should then be used as a replacement. Fuel pump type is free. An extra loop of pipe may be used as a return feed to the tank. Inline fuel filters may be fitted.

### **Con-rod**

The standard con-rod may be retained, but alternatively an ARC billet conrod with renewable shells may be fitted by a NatSKA approved supplier.

### **Exhaust**

The standard exhaust should be retained, but may be debaffled by a NatSKA approved supplier. The exhaust studs may be replaced if required. A silencer support bracket may also be added (the design of which is free).

### **Ignition coil and timing**

The standard ignition coil, bolts and mounting position should be retained. A modified flywheel key may be fitted by a NatSKA approved supplier, that offers no more than 6 degrees of ignition advance.

### **Clutch, chain and sprockets**

The clutch can be any dry, air-cooled centrifugal drum-type clutch. The clutch bore is to be 1"/25.4mm. The clutch should be in standard form, except clutch springs which are not restricted, and be incapable of adjustment in position on the engine. The final drive chain and sprocket pitch are free.

### **Engine machining**

The piston may be machined flat by 0.085" (the standard piston is dished) to achieve a flush deck height by a NatSKA approved supplier.

### **Carburettor and jets**

The main jet may be replaced with a 100 size main jet.

### **Valve Springs**



Standard valve springs may be replaced with 18lb springs by a NatSKA approved supplier.

### **Spark Plugs**

The spark plug should be either a NGK BPR6ES, BP6ES, BP5ES or BPR5ES or compatible equivalent (eg; DENSO W20EP-U,W20EPR-U,W16EP-U or W16EPR-U). In all cases the plug should remain standard and unmodified.

### **Sealing**

The engine must be sealed by a NatSKA approved supplier, and the seals fitted must remain intact at all times. Any work that requires the removal of seals is to be carried out by a NatSKA approved resealer, or in Parc-Ferme under supervision of an authorised NatSKA resealer. Seals will be fitted to the rocker, crankcase and flywheel covers, as well as to any other part of the engine also deemed necessary by the NatSKA approved supplier/resealer. The seal numbers will be recorded in a NatSKA database/log book system.

### **Sealing locations**

Crankcase cover sealing bolts

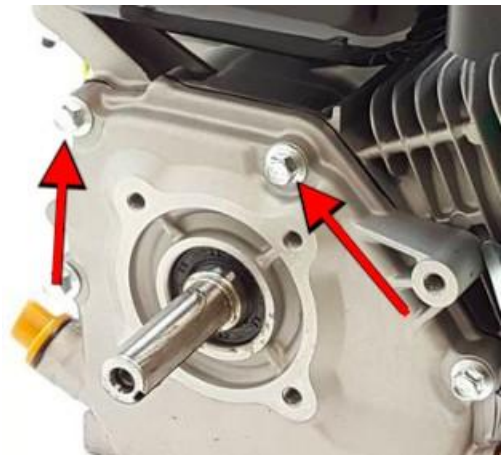

Flywheel cover sealing bolt and hole location

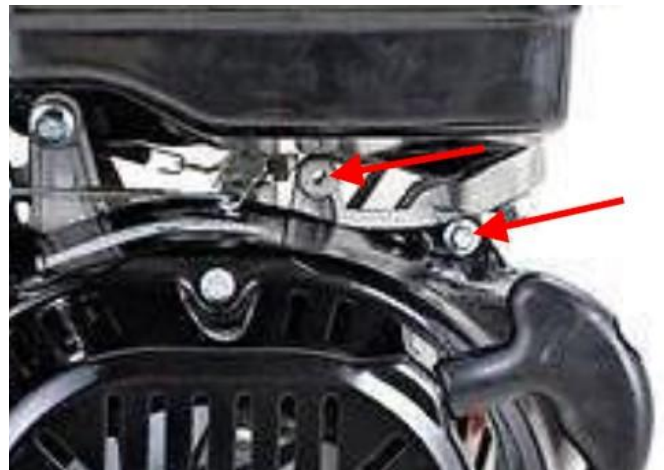

Rocker cover sealing bolt and tapped hole (hole will become available once standard throttle linkage is removed).





**Blue**  
Overtaking flag

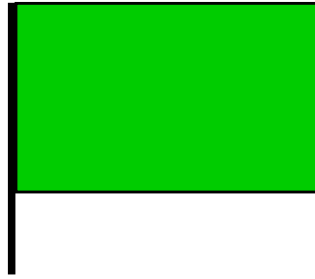

**Green**  
Road clear



**White**  
Service car or slow moving vehicle

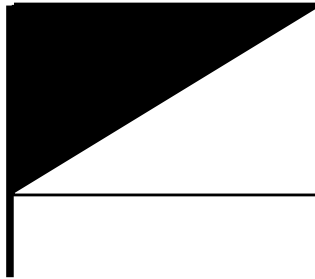

**Black/White diagonal**  
Warning flag

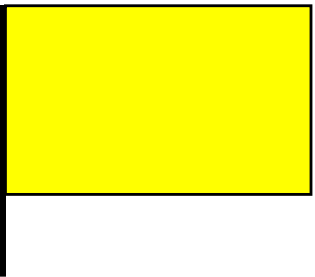

**Yellow**  
Danger, no overtaking



**Black/Orange disc**  
Mechanical failure

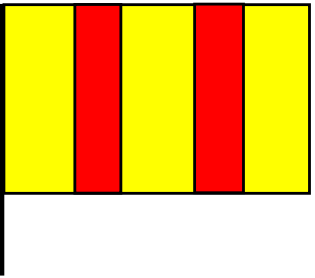

**Yellow/Red**  
Slippery surface



**Black**  
Report to CofC

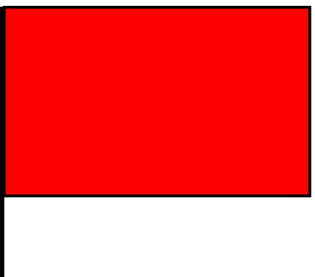

**Red**  
Stop racing

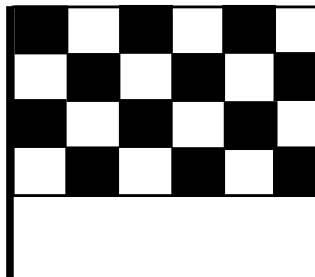

**Black/White chequered**  
End of race

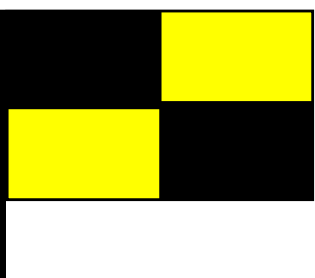

**Yellow/Black quartered**  
Slow down, no overtaking (karting only)

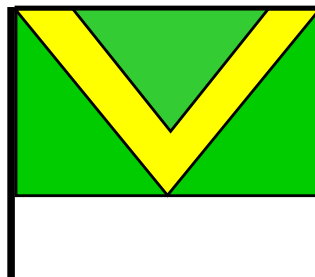

**Green/Yellow chevron**  
False start (karting only)